

P-4603
S1106
22132

GENERAL WALL THICKNESS = 1.30mm
F = FULL RADIUS (5 PLACES)

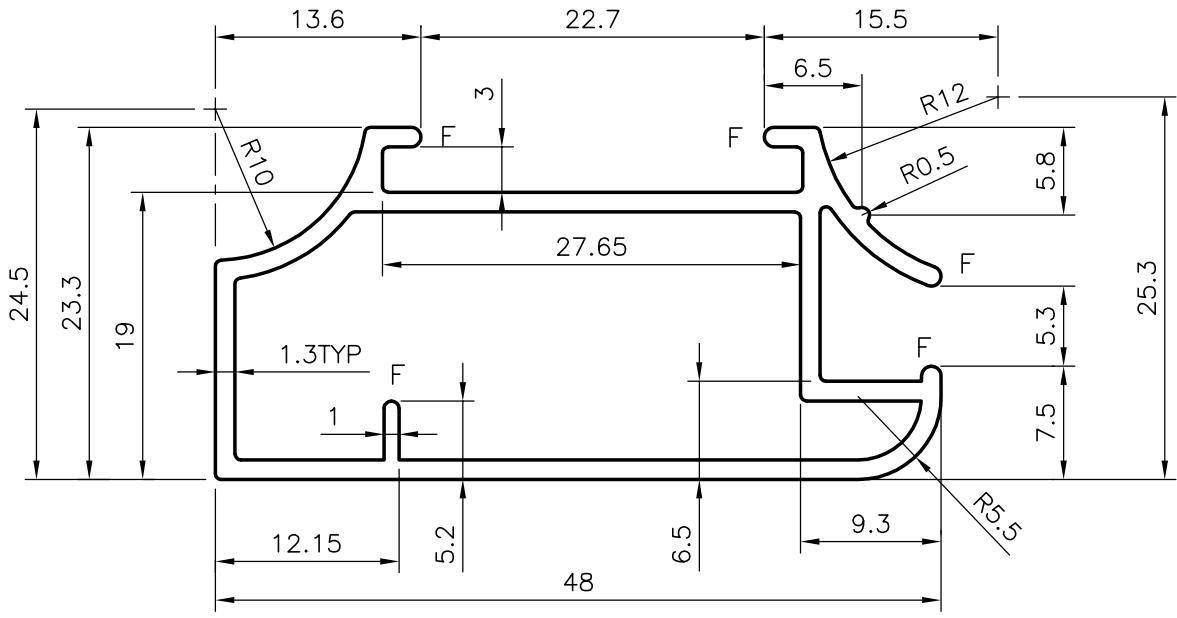
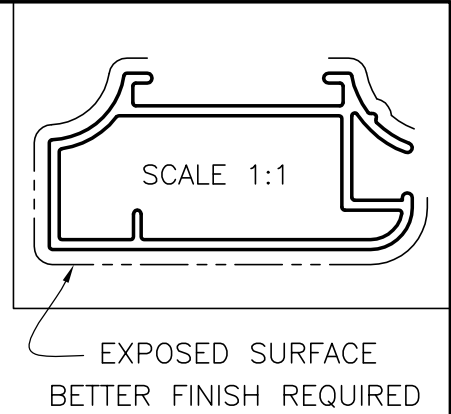

JINDAL ALUMINIUM LTD.
BANGALORE-560073 (INDIA)

	NAME	DATE
DRAWN	RAGHAVENDRA	01-12-2003
CHECKED		
APPROVED		

1. ALL DIMENSIONS ARE IN mm.
2. ROUND OFF ALL SHARP CORNERS WITH 0.40 mm.
3. TOLERANCES WILL BE AS PER IS: 6477-1983 UNLESS OTHERWISE SPECIFIED

SCALE	2:1 & 1:1
AREA mm ²	200.4
PERIMETER mm.	172.35
WEIGHT kg/m	0.540

PARTY'S NAME	RIVIERA INTERIORS, KERALA
PARTY'S DRAWING No.	AS PER SAMPLE
ALLOY & TEMPER	HE9 WP
DESCRIPTION	MISC. HOLLOW

DRAWING No.	SECTION No.
P-4603	-
S1106	S1106
22132	22132