

P-13705-1

22137

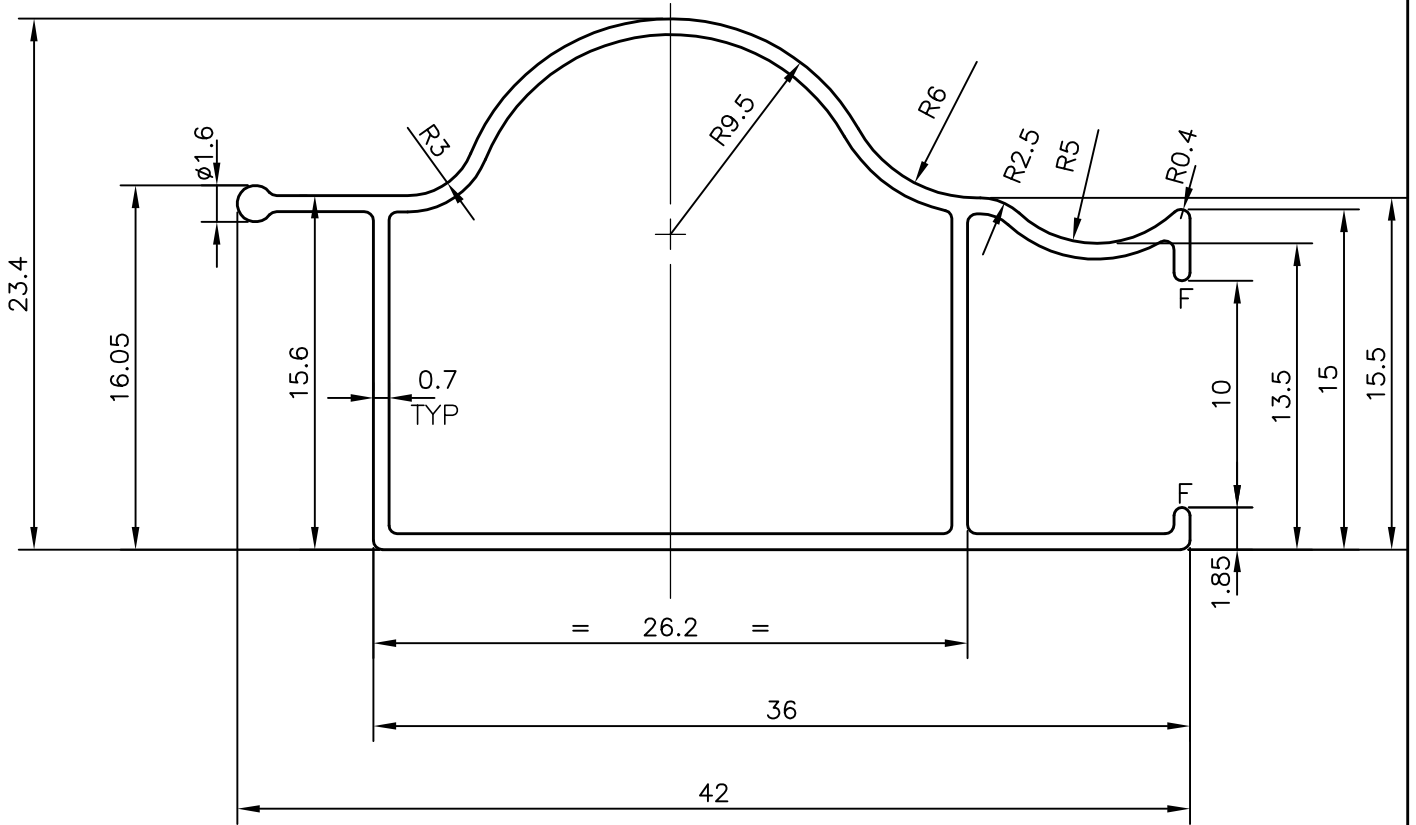
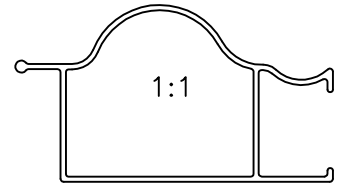

AVERAGE WEIGHT:- 0.820 kg/3658 mm

F = FULL RADIUS(2 PLACES)



SYMBOL OF QUALITY
AN ISO 9001 COMPANY

JINDAL ALUMINIUM LTD.
BANGALORE-560073 (INDIA)

	NAME	DATE
DRAWN	J.P.KAUSHIK	22-07-2014
CHECKED		
APPROVED	S.S.GARG	28-07-2014
SCALE		3:1
AREA mm ²		82.937
PERIMETER mm.		147.4
WEIGHT kg/m		0.224
DRAWING No.		SECTION No.
P-13705-1		-
22137		22137

1. ALL DIMENSIONS ARE IN mm.
2. ROUND OFF ALL SHARP CORNERS WITH 0.40 mm.
3. TOLERANCES WILL BE AS PER IS:6477-1983, UNLESS OTHERWISE SPECIFIED

PARTY'S NAME	GENERAL CATEGORY , COCHIN MARKET
PARTY'S DRAWING No.	AS PER SAMPLE & REQUIREMENT
ALLOY & TEMPER	HE9 WP
DESCRIPTION	KITCHEN CABINET SECTION