

P-13773

22139

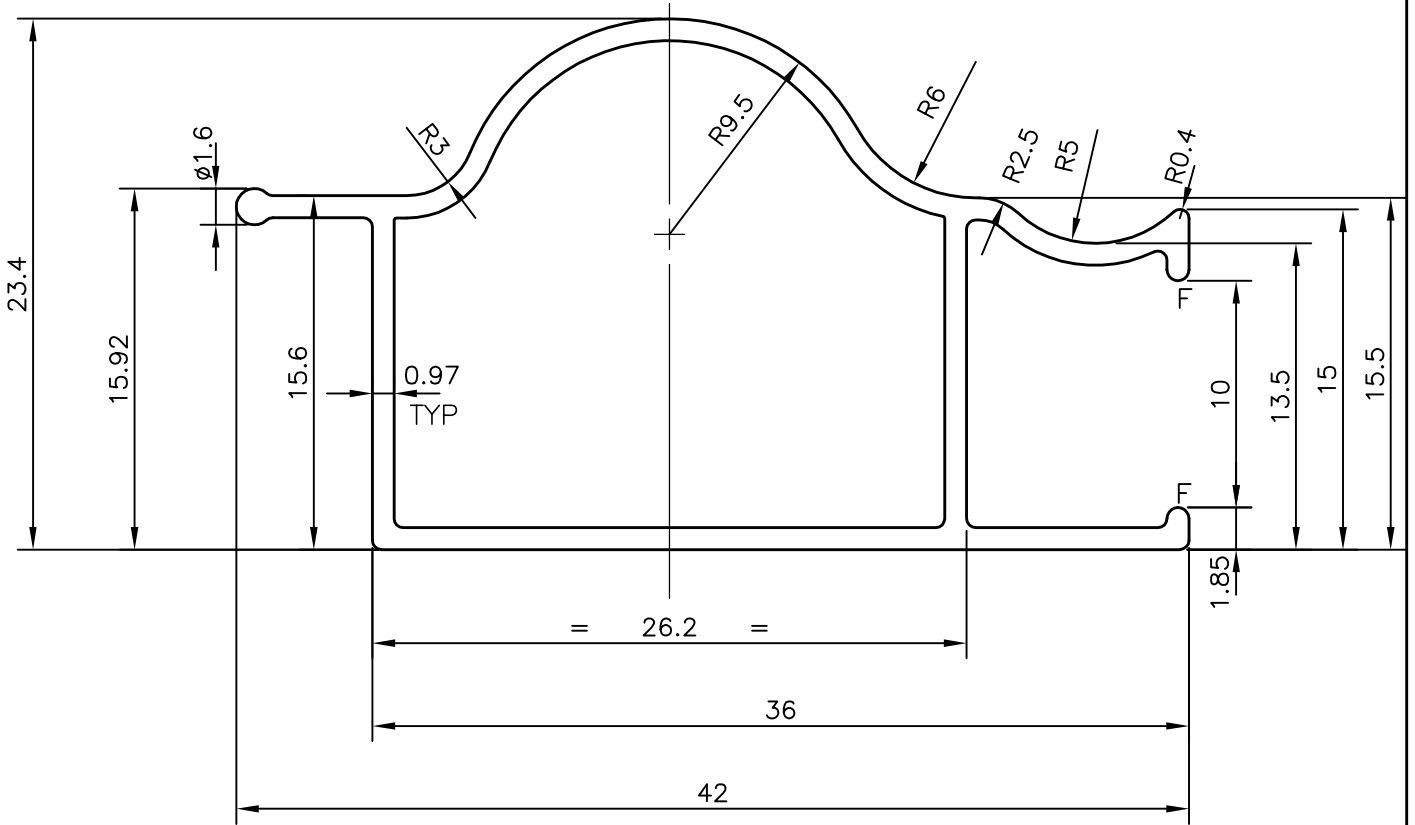
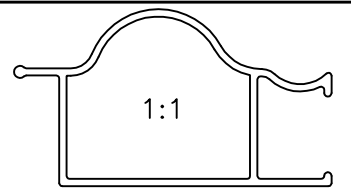

AVERAGE WEIGHT:- 1.108 kg/3658 mm

F = FULL RADIUS(2 PLACES)



SYMBOL OF QUALITY  
AN ISO 9001 COMPANY

**JINDAL ALUMINIUM LTD.**  
BANGALORE-560073 (INDIA)

	NAME	DATE
DRAWN	J.P.KAUSHIK	22-07-2014
CHECKED		
APPROVED	S.S.GARG	28-07-2014
SCALE		3:1
AREA mm <sup>2</sup>		112.234
PERIMETER mm.		145.477
WEIGHT kg/m		0.303
DRAWING No.		SECTION No.
P-13773		-
22139		22139

1. ALL DIMENSIONS ARE IN mm.
2. ROUND OFF ALL SHARP CORNERS WITH 0.40 mm.
3. TOLERANCES WILL BE AS PER IS:6477-1983, UNLESS OTHERWISE SPECIFIED

PARTY'S NAME	GENERAL CATEGORY , COCHIN MARKET
PARTY'S DRAWING No.	AS PER SPECIFICATION
ALLOY & TEMPER	HE9 WP
DESCRIPTION	KITCHEN CABINET SECTION