

P-14500

22142

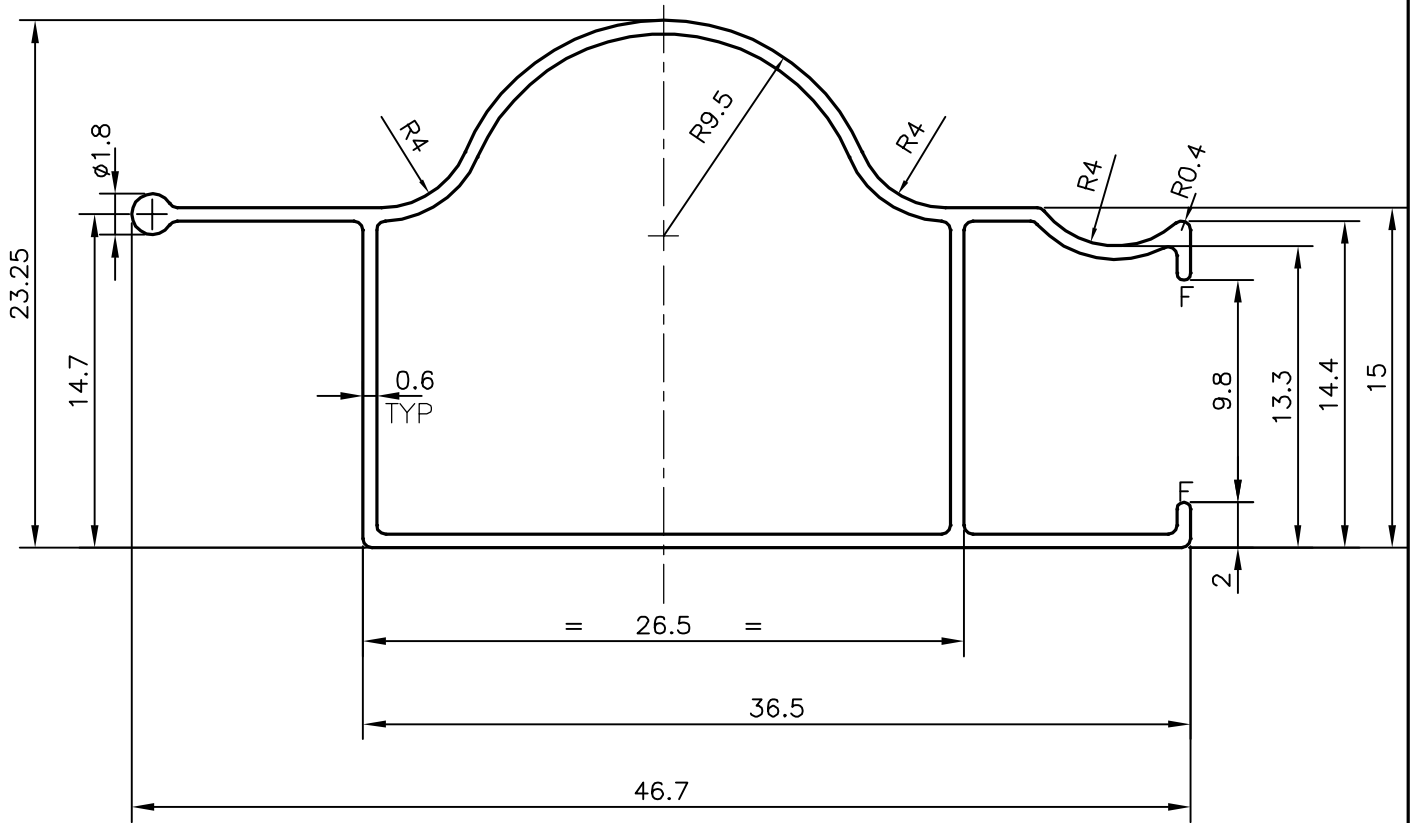

F = FULL RADIUS(2 PLACES)

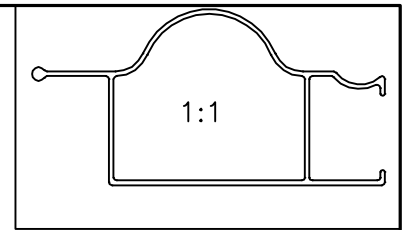

SYMBOL OF QUALITY
AN ISO 9001 COMPANY

JINDAL ALUMINIUM LTD.
BANGALORE-560073 (INDIA)

	NAME	DATE
DRAWN	J.P.KAUSHIK	26-03-2015
CHECKED		
APPROVED	S.S.GARG	09-07-2015
SCALE		3:1
AREA	mm ²	74.72
PERIMETER	mm.	156.757
WEIGHT	kg/m	0.202
DRAWING No.	SECTION No.	
P-14500	-	
22142	22142	

1. ALL DIMENSIONS ARE IN mm.
2. ROUND OFF ALL SHARP CORNERS WITH 0.40 mm.
3. TOLERANCES WILL BE AS PER IS:6477-1983, UNLESS OTHERWISE SPECIFIED

PARTY'S NAME	GENERAL CATEGORY, COCHIN MARKET
PARTY'S DRAWING No.	AS PER SAMPLE & REQUIREMENT
ALLOY & TEMPER	HE9 WP
DESCRIPTION	KITCHEN CABINET SECTION