

P-21683

22158

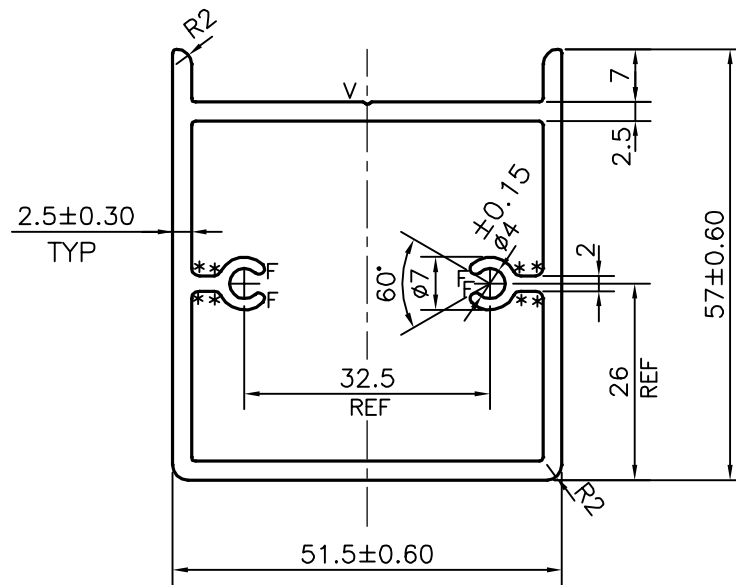

* = 1.0 RADIUS (8 PLACES)

F = FULL RADIUS (4 PLACES)

UNSPECIFIED RADIUS 0.5 mm

V = V GROOVE 0.3x90° (1 PLACE)

AVERAGE WEIGHT:-1.357 kg/m TO 1.728 kg/m



SYMBOL OF QUALITY
AN ISO 9001 COMPANY

JINDAL ALUMINIUM LTD.
BANGALORE-560073 (INDIA)

	NAME	DATE
DRAWN	J.P.KAUSHIK	16-10-2020
CHECKED		
APPROVED	B.NATARAJA	29-10-2020

1. ALL DIMENSIONS ARE IN mm.
2. ROUND OFF ALL SHARP CORNERS WITH 0.40 mm.
3. TOLERANCES WILL BE AS PER IS:6477-1983 , UNLESS OTHERWISE SPECIFIED

SCALE	1:1
AREA mm ²	571.641
PERIMETER mm.	226.896
WEIGHT kg/m	1.543

PARTY'S NAME	K.K. IMPEX, GURGAON
--------------	---------------------

DRAWING No.	SECTION No.
-------------	-------------

PARTY'S DRAWING No.	PROFILE-2
---------------------	-----------

P-21683	-
22158	22158

ALLOY & TEMPER	6063 T6
----------------	---------

DESCRIPTION	MISC. SECTION
-------------	---------------