

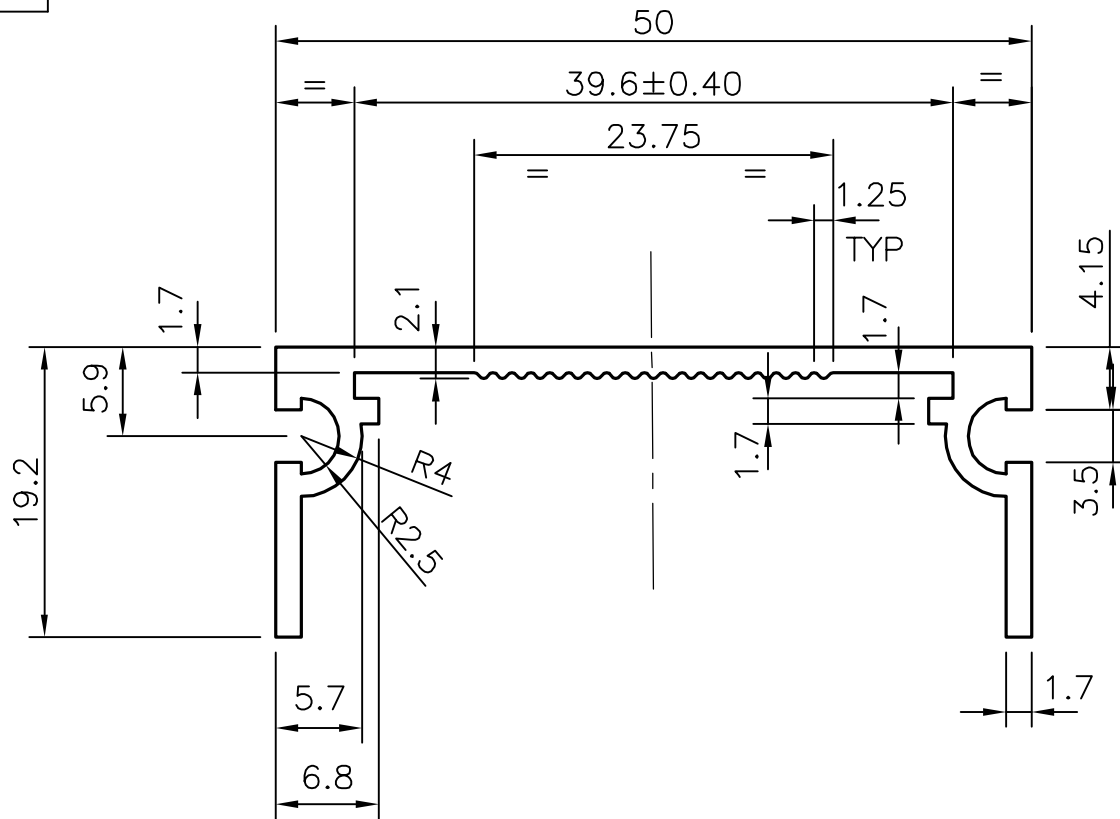

P-4184
S986
7129
22224
X561
22224

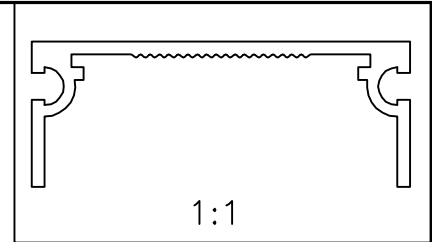

1. UNSPECIFIED GENERAL WALL THICKNESS:- 1.70 mm.

 SYMBOL OF QUALITY AN ISO 9002 COMPANY	JINDAL ALUMINIUM LTD. BANGALORE-560073 (INDIA)	NAME	DATE
		DRAWN	R.D.Sharma 27-03-03
		CHECKED	
1. ALL DIMENSIONS ARE IN mm. 2. ROUND OFF ALL SHARP CORNERS WITH 0.40 mm. 3. TOLERANCES WILL BE AS PER IS: 3965-1981 UNLESS OTHERWISE SPECIFIED		APPROVED	
		SCALE	2:1
		AREA mm ²	178.4
PARTY'S NAME	UNITED INSULATION, MUMBAI	PERIMETER mm.	200.3
PARTY'S DRAWING No.	UI-ALUM SEC 4	WEIGHT kg/m	0.482
ALLOY & TEMPER	HE9 WP	SECTION No.	22224
DESCRIPTION	AXIOM 50 mm.	DRAWING No.	22224