

P-2351
8119
22248

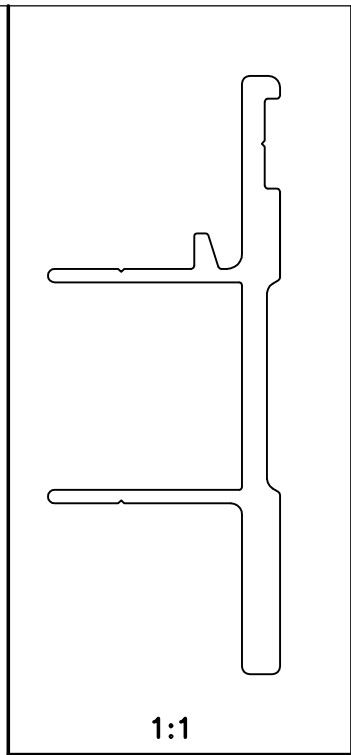
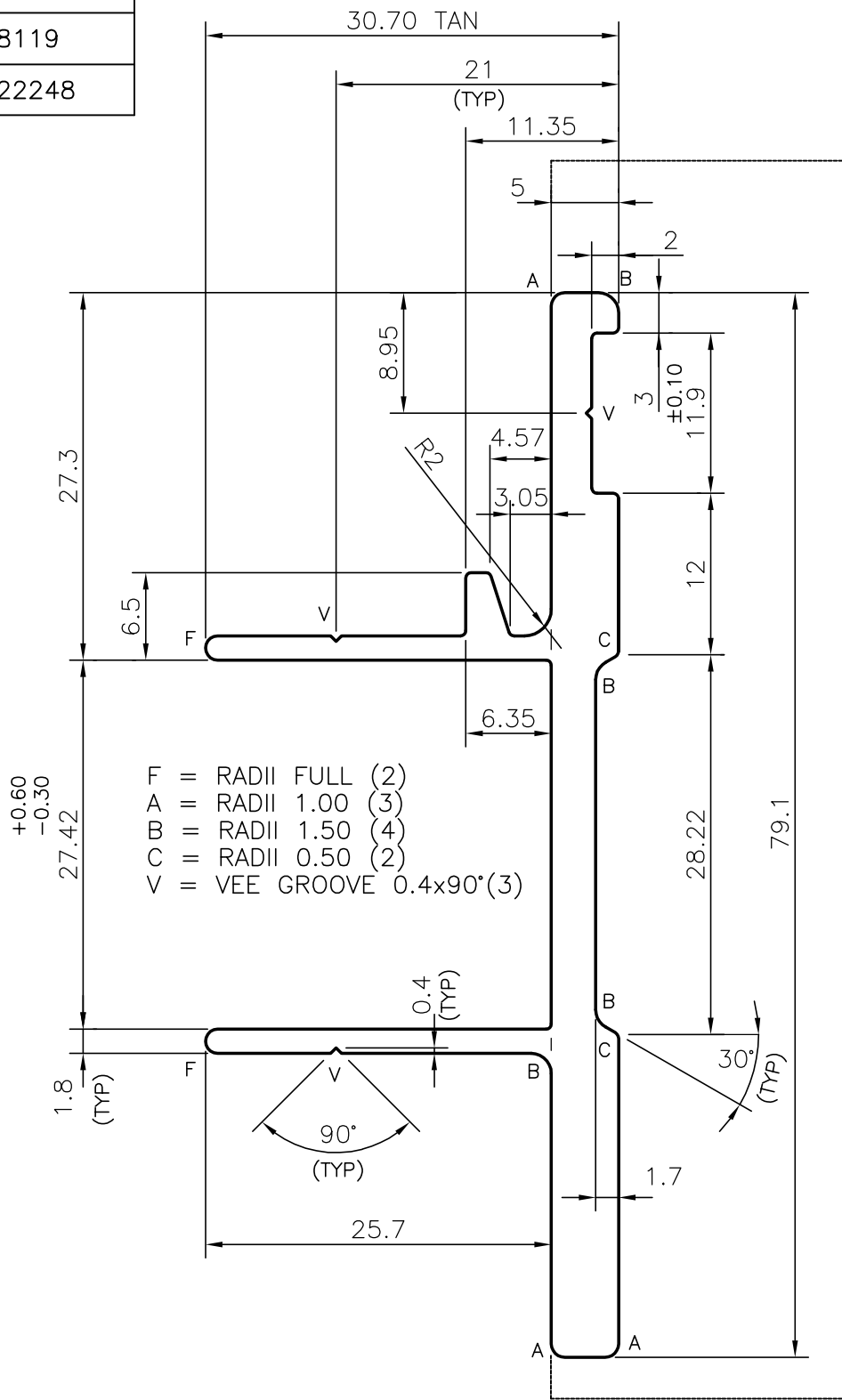

EXPOSED SURFACE

JINDAL ALUMINIUM LTD.
 BANGALORE-560073

1. ALL DIMENSIONS ARE IN mm.
 2. ROUND OFF ALL SHARP CORNERS WITH 0.4 mm.
 3. TOLERANCES WILL BE AS PER BS:1474-1987 UNLESS OTHERWISE SPECIFIED

		NAME	DATE
		DRAWN	P,KULKARNI 13-5-99
		CHECKED	
		APPROVED	
PARTY'S NAME	APPLE ALUMINIUM., AUSTRALIA	SCALE	2:1
PARTY'S DRAWING No.	APE 214	WEIGHT kg/m	1.158
ALLOY & TEMPER	6063 T6	SECTION No.	22248
LENGTH	4940 mm, 4640 mm, & 5680 mm.	DRAWING No.	22248
DESCRIPTION	GEN MISC SOLID PROFILE		