

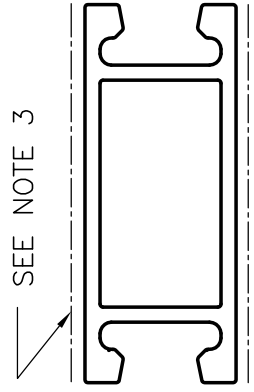

P-3035-3  
8172  
22268

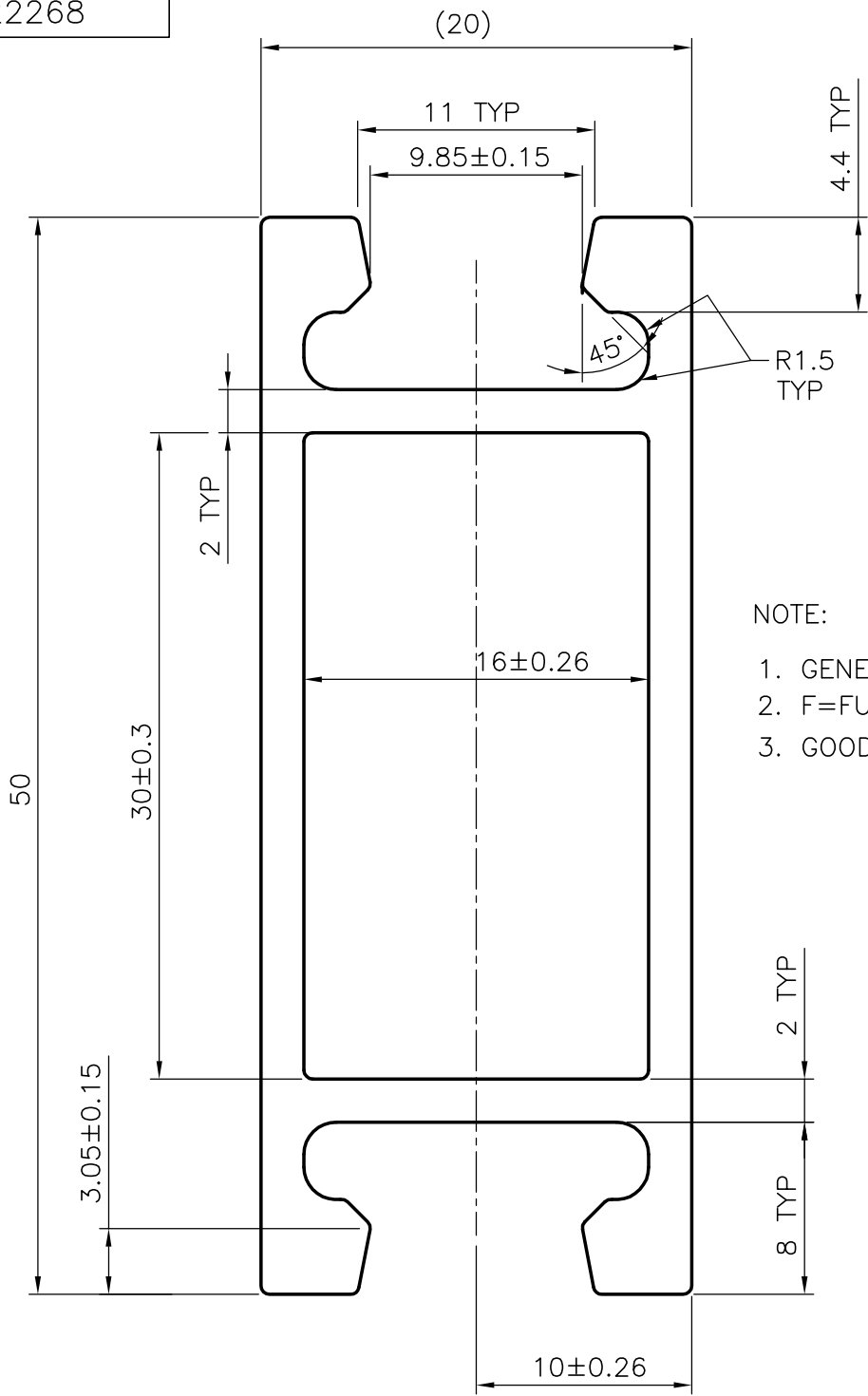

SCALE 1:1

- NOTE:
1. GENERAL WALL THICKNESS = 2.0mm.
  2. F=FULL RADII 1mm (1-PLCS)
  3. GOOD FINISH REQUIRED

PERIMETER 186.03

 SYMBOL OF QUALITY AN ISO 9002 COMPANY	<b>JINDAL ALUMINIUM LTD.</b> BANGALORE-560073 (INDIA)	NAME	DATE
		DRAWN	RANGASWAMY 22-02-01
1. ALL DIMENSIONS ARE IN mm. 2. ROUND OFF ALL SHARP CORNERS WITH 0.40 mm. 3. TOLERANCES WILL BE AS PER B.S 1474-1987 UNLESS OTHERWISE SPECIFIED		CHECKED	
		APPROVED	
PARTY'S NAME	Hi-TECH CONTRACTS- U.K	SCALE	3:1 & 1:1
PARTY'S DRAWING No.	AS PER DRAWING (H50)	WEIGHT kg/m	0.852
ALLOY & TEMPER	6063 T6	SECTION No.	22268
DESCRIPTION	GENERAL MISC	DRAWING No.	22268