

S697
8206
22280

DETAIL A
SCALE 5:1

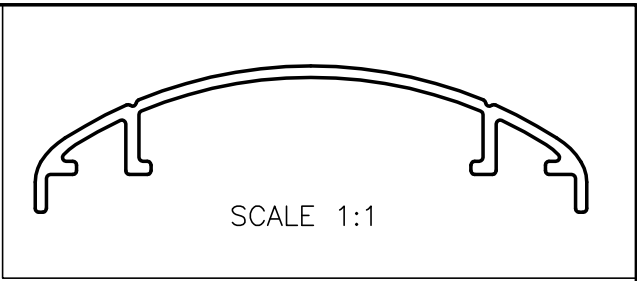
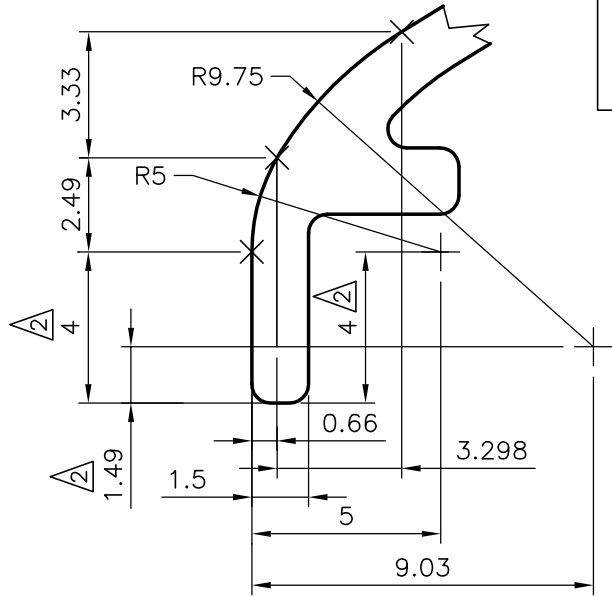

\triangle = DIMENSION CHANGED FROM
3.00 TO 5.00
17.35 TO 19.35
2.00 TO 4.00
2.00 TO 4.00
0.51 TO 1.49

AND WEIGHT ALSO CHANGED FROM
0.458kg/m TO 0.482kg/m

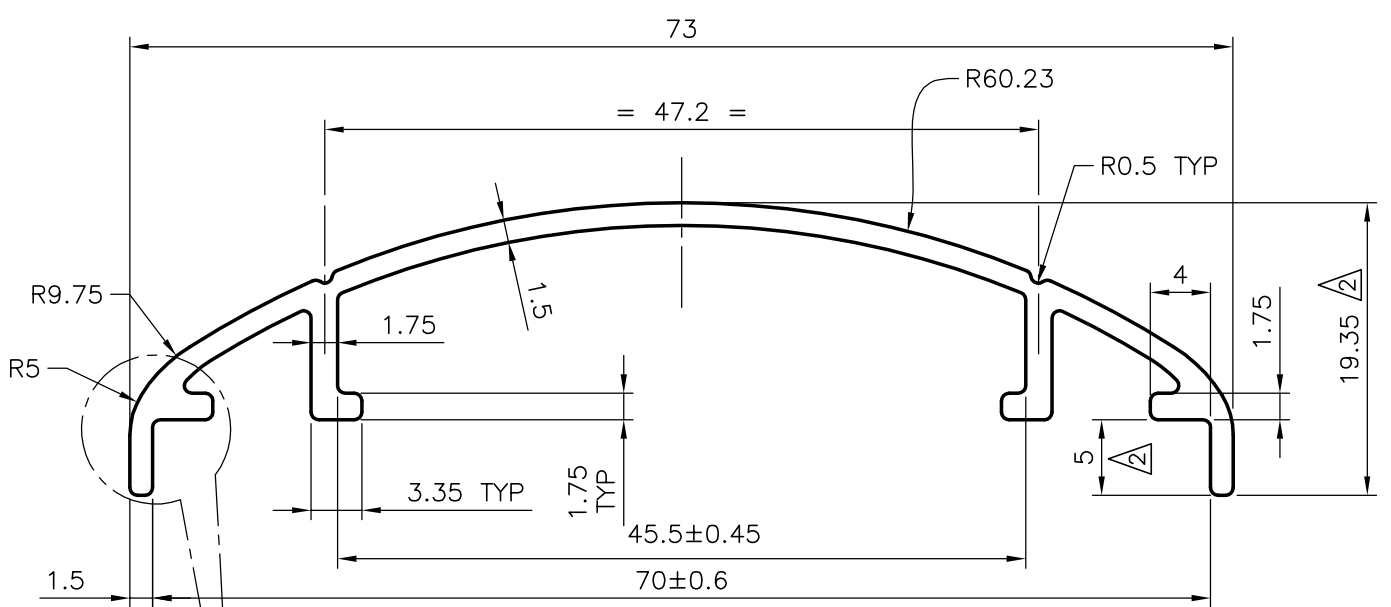

DETAIL A

NOTE:-

1. GENERAL WALL THICKNESS :-1.5mm
2. ALL THE CORNER SHOULD BE R0.5mm RADII.

S697

 SYMBOL OF QUALITY AN ISO 9002 COMPANY	JINDAL ALUMINIUM LTD. BANGALORE-560073 (INDIA)	NAME	DATE
		DRAWN	RAGHAVENDRA 15-09-01
		CHECKED	
1. ALL DIMENSIONS ARE IN mm. 2. ROUND OFF ALL SHARP CORNERS WITH 0.40 mm. 3. TOLERANCES WILL BE AS PER IS: 3965-1981 UNLESS OTHERWISE SPECIFIED		APPROVED	
		SCALE	2:1 & 1:1
PARTY'S NAME	FETHERLIGHT OFFICE SYSTEMS (P) LIMITED., BANGALORE	WEIGHT kg/m	0.482
PARTY'S DRAWING No.	AS PER DRAWING NO. 1 & 2	SECTION No.	22280
ALLOY & TEMPER	HE9 WP	DRAWING No.	
DESCRIPTION	-	22280	