

S397

8281

22296

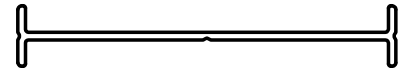

1:1

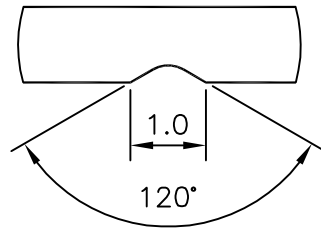

'V' GROOVE DETAIL
(10:1)

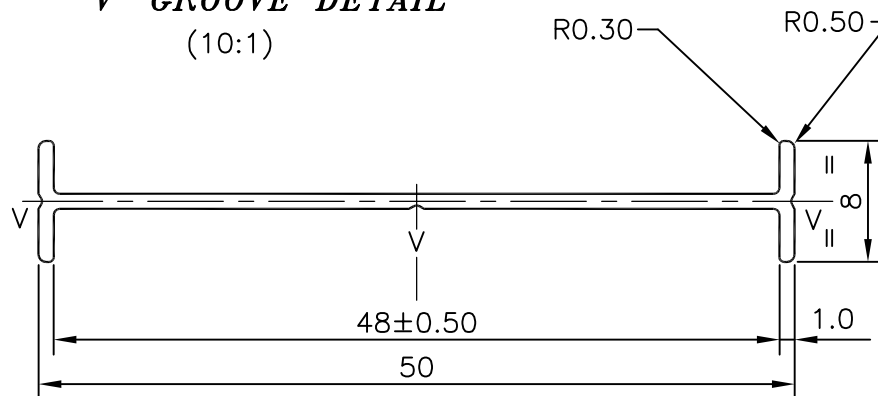

GENERAL WALL THICKNESS :- 1.0 mm.

V = VEE GROOVE (3)

LENGTH = 3660 mm.



SYMBOL OF QUALITY
AN ISO 9002 COMPANY

JINDAL ALUMINIUM LTD.
BANGALORE-560073 (INDIA)

	NAME	DATE
DRAWN	R.D.Sharma	16-06-98
CHECKED		
APPROVED		
SCALE	2:1	
WEIGHT kg/m	0.171	
SECTION No.	22296	
DRAWING No.	22296	

1. ALL DIMENSIONS ARE IN mm.
2. ROUND OFF ALL SHARP CORNERS WITH 0.40 mm.
3. TOLERANCES WILL BE AS PER IS 3965-1981 UNLESS OTHERWISE SPECIFIED

PARTY'S NAME **GODREJ & BOYCE MFG. CO. LTD., MUMBAI**

PARTY'S DRAWING No. **PL4-A4-617 (REV.-A) ('I' SECTION)**

ALLOY & TEMPER **HE9 WP**

DESCRIPTION **GENERAL MISCELLANEOUS**