

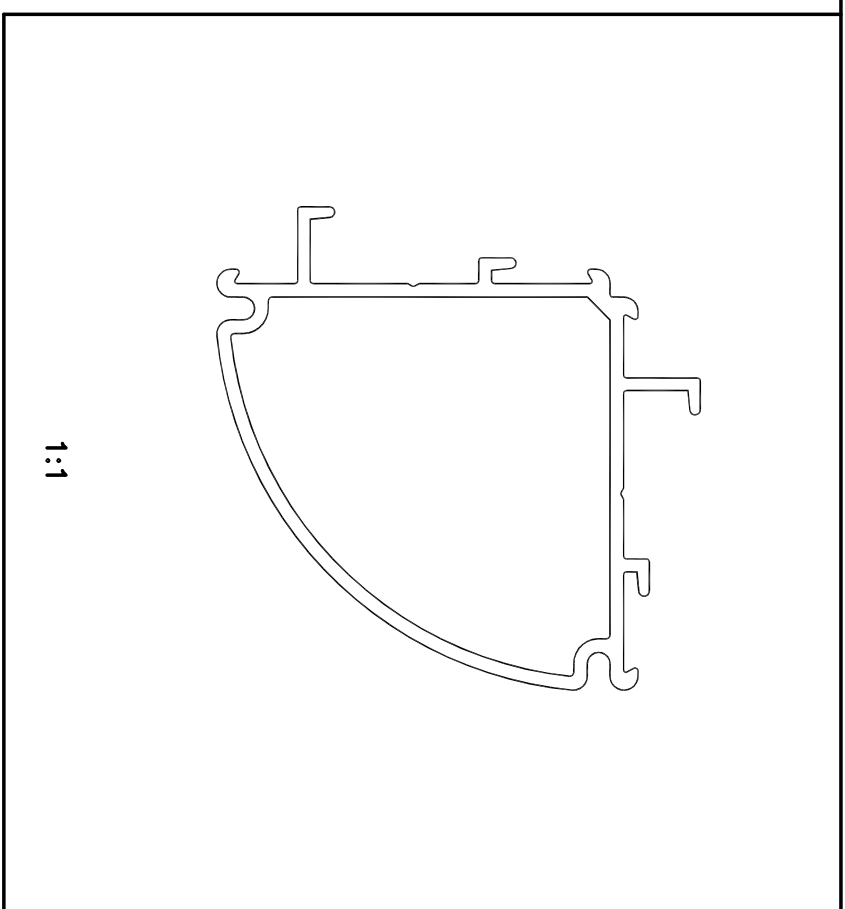

CUTTING LENGTH = 1318 mm

- C = RADII 0.50 (4)
- Z = RADII 0.40 (5)
- R = RADII 0.30 (4)
- F = RADII FULL (8)
- K = RADII 1.85 (4)
- V = VEE GROOVE (2)



 SYMBOL OF QUALITY AN ISO 9002 COMPANY		JINDAL ALUMINIUM LTD. BANGALORE-560073 (INDIA)		NAME	DATE
1. ALL DIMENSIONS ARE IN mm. 2. ROUND OFF ALL SHARP CORNERS WITH 0.40 mm. 3. TOLERANCES WILL BE AS PER IS 6477-1983 UNLESS OTHERWISE SPECIFIED				DRAWN	P.KULKARNI
PARTY'S NAME		GODREJ & BOYCE MFG CO LTD., MUMBAI		CHECKED	
PARTY'S DRAWING No.		PL4-A3-539A (2 WAY 90)		APPROVED	
ALLOY & TEMPER		HE9 WP (63400 WP)		SCALE	2:1
DESCRIPTION		GENERAL MISCELLANEOUS		WEIGHT kg/m	1.160
				SECTION No.	XXXX 22300
				DRAWING No.	XXXX 22300