

9166

22311

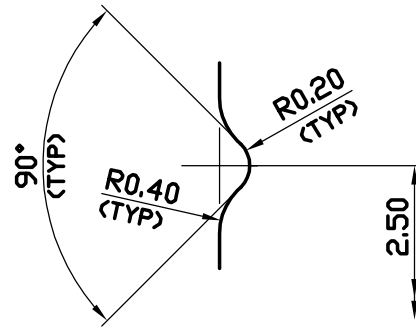

DETAILS "A"
SCALE = 20:1

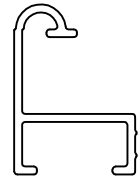

1:1

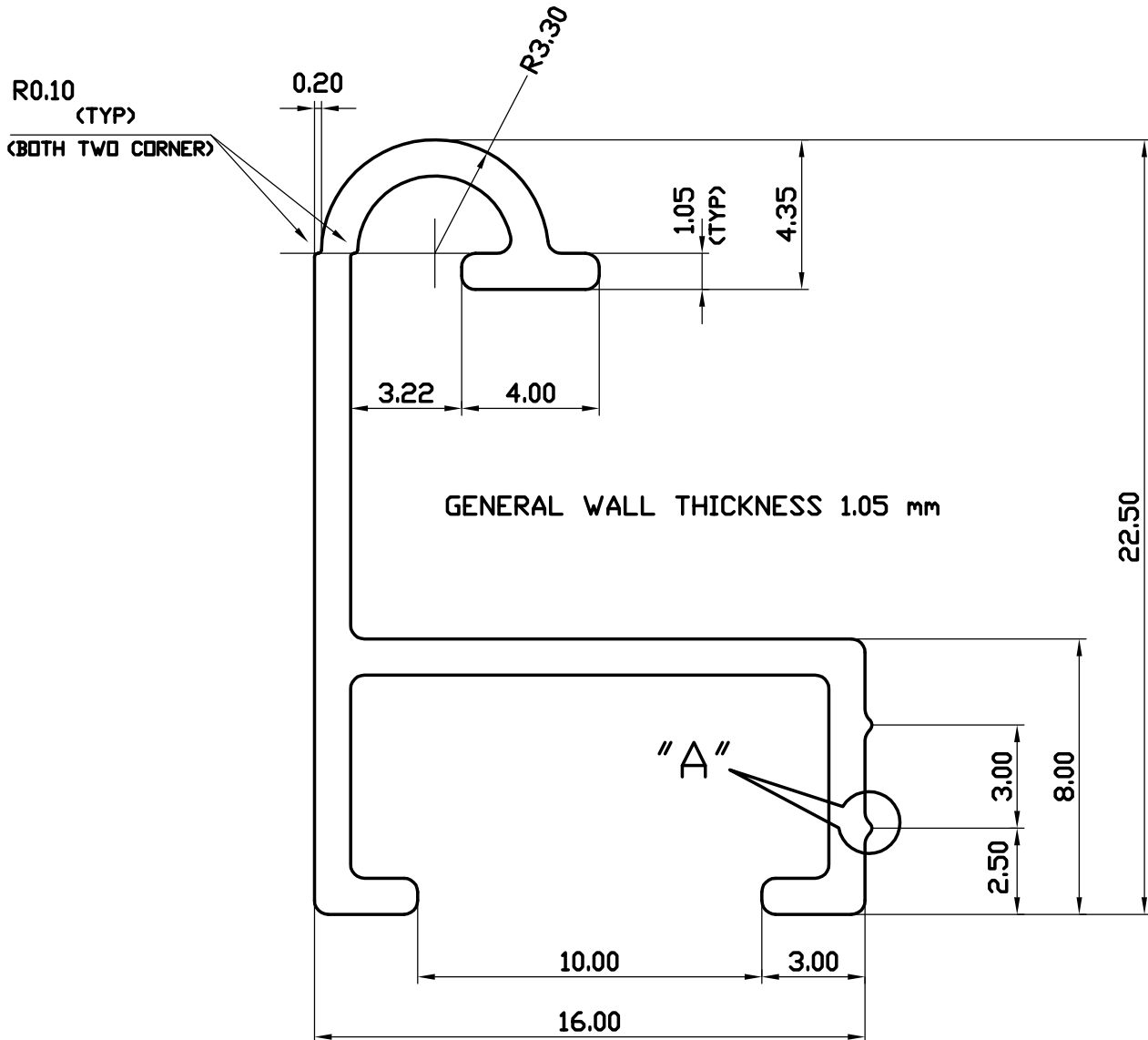

SYMBOL OF QUALITY
AN ISO 9002 COMPANY

JINDAL ALUMINIUM LTD.
BANGALORE-560073 (INDIA)

	NAME	DATE
DRAWN	P,KULKARNI	29-3-2K
CHECKED		
APPROVED		
SCALE	5:1	
WEIGHT kg/m	0.163	
SECTION No.	22311	
DRAWING No.	22311	

1. ALL DIMENSIONS ARE IN mm.
2. ROUND OFF ALL SHARP CORNERS WITH 0.40 mm.
3. TOLERANCES WILL BE AS PER IS:3965-1981 UNLESS OTHERWISE SPECIFIED

PARTY'S NAME	GENERAL CATEGORY (PUNE MARKET)
PARTY'S DRAWING No.	AS PER SAMPLE
ALLOY & TEMPER	HE9 WP
DESCRIPTION	INDUSTRIAL MISC SECTION