

P-1544

9146

22325

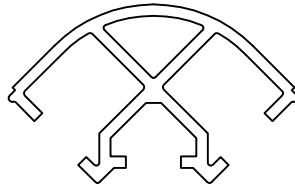

1:1

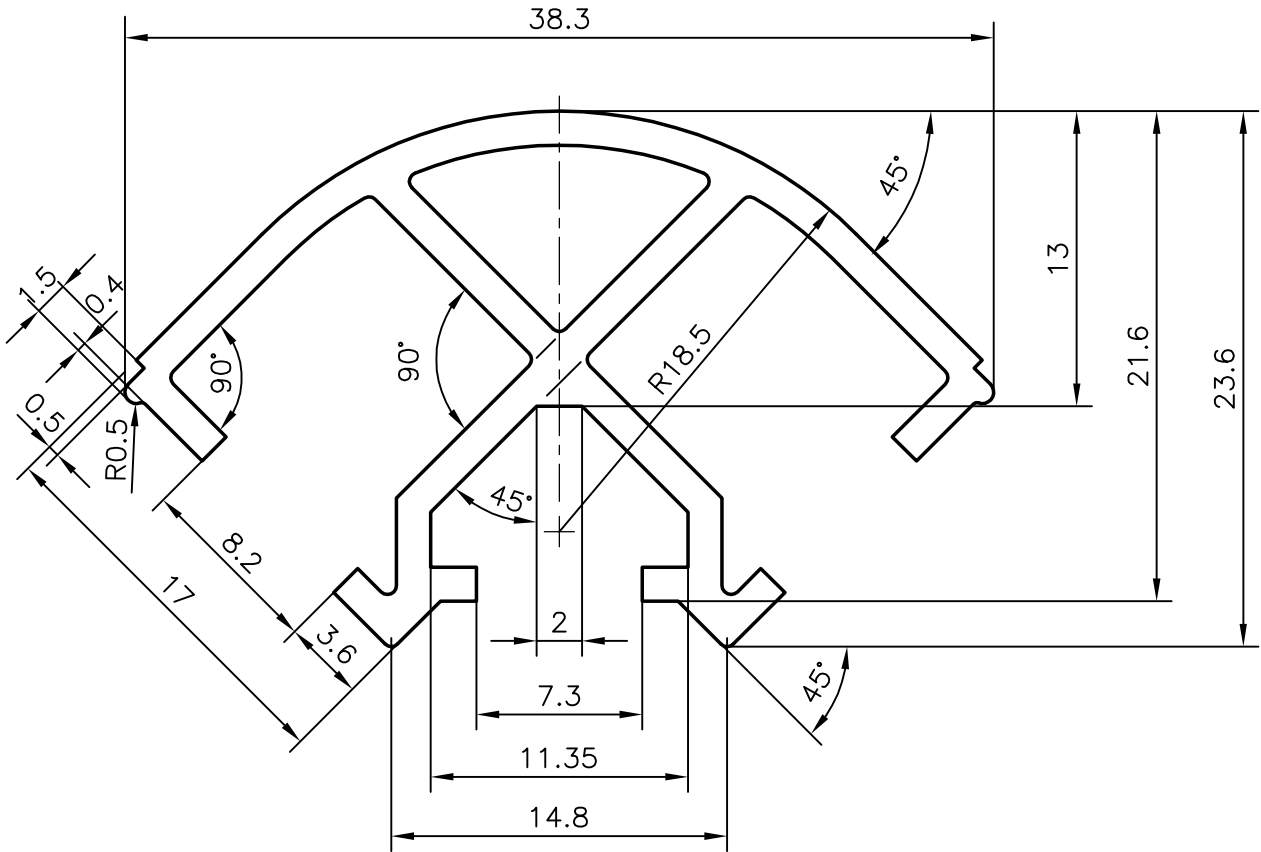

GENERAL WALL THICKNESS:- 1.50 mm.

JINDAL ALUMINIUM LTD.
BANGALORE-560073

	NAME	DATE
DRAWN	R.D.Sharma	13-05-96
CHECKED		
APPROVED		
PARTY'S NAME	REVANT OVERSEAS, JALANDHAR/ ELECTRO MASTER TRADING, DUBAI	
PARTY'S DRAWING No.	CODE A2	
ALLOY & TEMPER	HE9 WP (6063 T6)	
LENGTH	5850 mm.	
DESCRIPTION	-	
SCALE		1:1 & 3:1
WEIGHT kg/m		0.460
SECTION No.		22325
DRAWING No.		22325

1. ALL DIMENSIONS ARE IN mm.
2. ROUND OFF ALL SHARP CORNERS WITH 0.4 mm.
3. TOLERANCES WILL BE AS PER IS: 6477-1983 ,UNLESS OTHERWISE SPECIFIED