

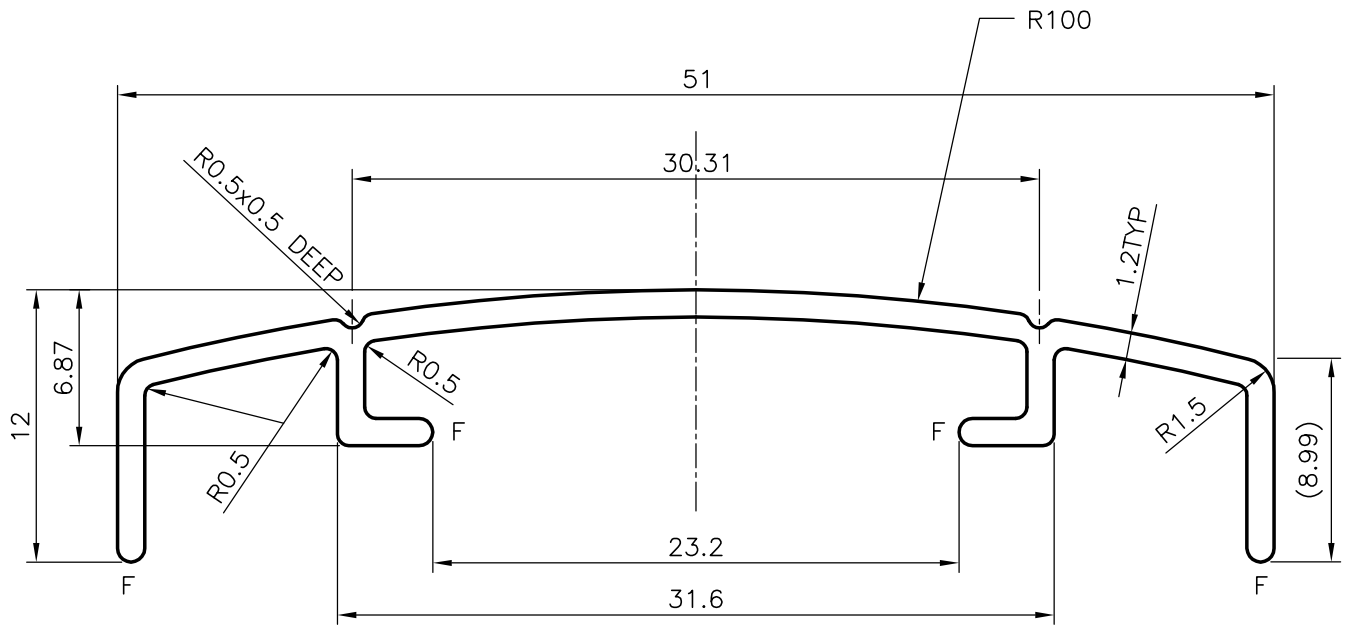

P-4781
S1170
22326

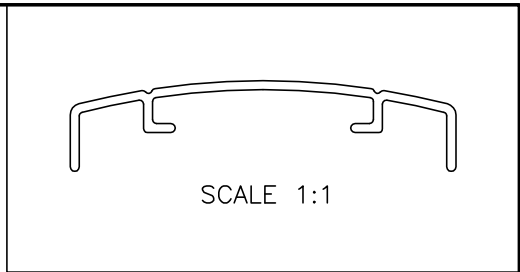

GENERAL WALL THICKNESS = 1.20mm
 F = FULL RADIUS (4 PLACES)
 REMOVE BURRES AND SHARP EDGES

 SYMBOL OF QUALITY AN ISO 9002 COMPANY	JINDAL ALUMINIUM LTD. BANGALORE-560073 (INDIA)	NAME		DATE
		DRAWN	RAGHAVENDRA	05-03-2004
1. ALL DIMENSIONS ARE IN mm. 2. ROUND OFF ALL SHARP CORNERS WITH 0.50 mm. 3. TOLERANCES WILL BE AS PER IS:3965-1981 UNLESS OTHERWISE SPECIFIED		CHECKED		
		APPROVED		
PARTY'S NAME 21st CENTURY OFFICES, BANGALORE		SCALE		3:1
		AREA mm ²		96.274
PARTY'S DRAWING No. 10206816		PERIMETER mm.		161.624
		WEIGHT kg/m		0.260
ALLOY & TEMPER HE9 WP		DRAWING No.		SECTION No.
		P-4781		-
DESCRIPTION FURNITURE SECTION		S1170		S1170
		22326		22326