

P-4505

S1077

22340

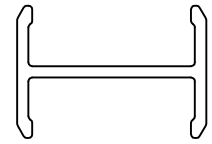

1:1

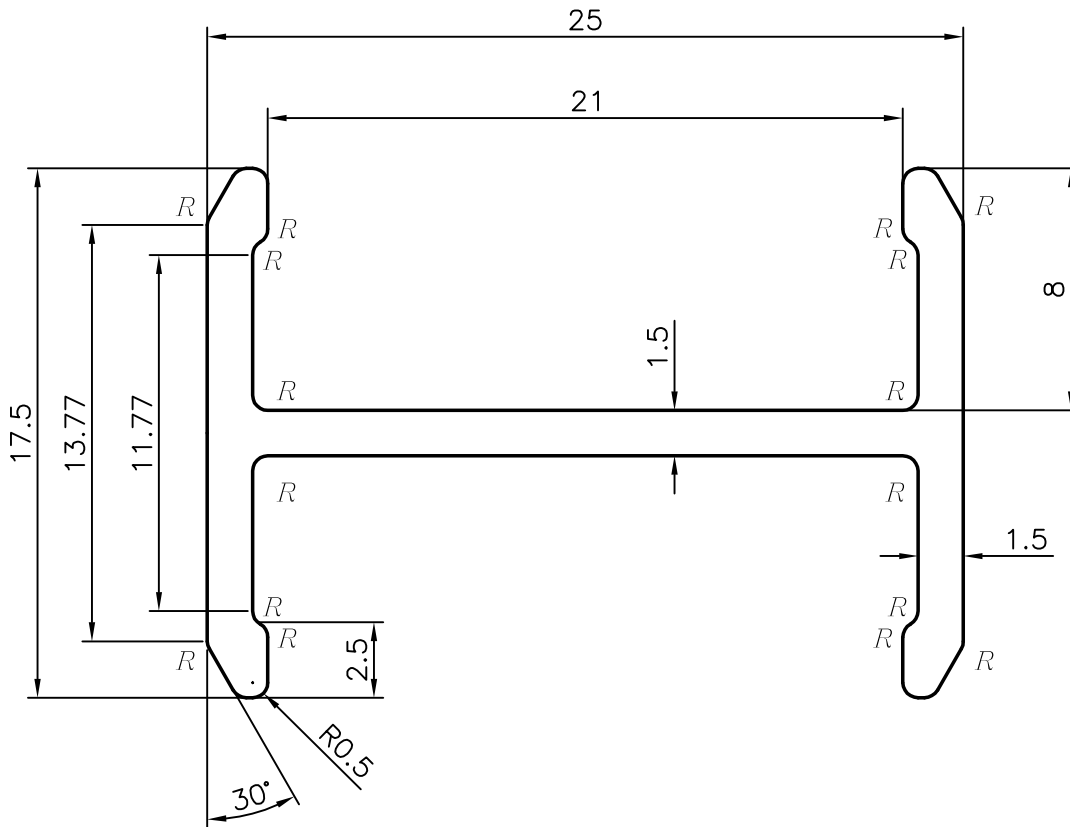

$R = R0.5$

GENERAL WALL THICKNESS = 1.5mm



SYMBOL OF QUALITY
AN ISO 9002 COMPANY

JINDAL ALUMINIUM LTD.
BANGALORE-560073 (INDIA)

	NAME	DATE
DRAWN	MALINGAPPA	17.10.2003
CHECKED		
APPROVED		

1. ALL DIMENSIONS ARE IN mm.
2. ROUND OFF ALL SHARP CORNERS WITH 0.40 mm.
3. TOLERANCES WILL BE AS PER IS: 6477-1981 UNLESS OTHERWISE SPECIFIED

SCALE	4:1
AREA mm ²	86.9
PERIMETER mm.	114.9
WEIGHT kg/m	0.234

PARTY'S NAME	21st CENTURY OFFICES, BANGALORE
PARTY'S DRAWING No.	10205909
ALLOY & TEMPER	HE9,WP
DESCRIPTION	TITLE SEPARATOR TCO-500

DRAWING No.	SECTION No.
P-4505	-
S1077	S1077
22340	22340