

P-4409  
S1045  
22356

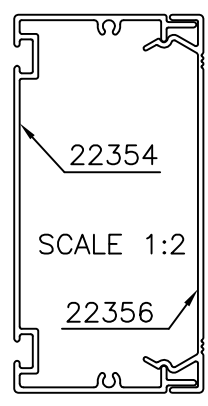

SCALE 1:2

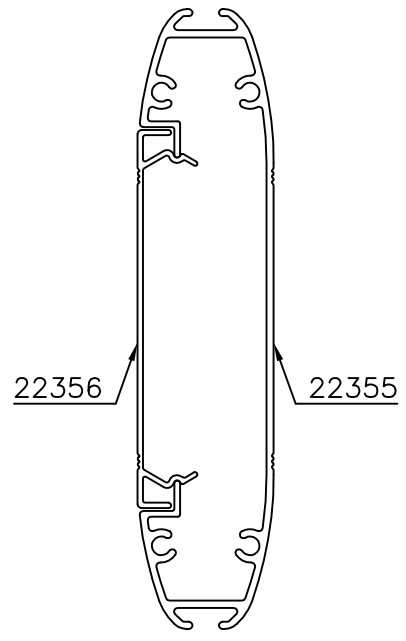
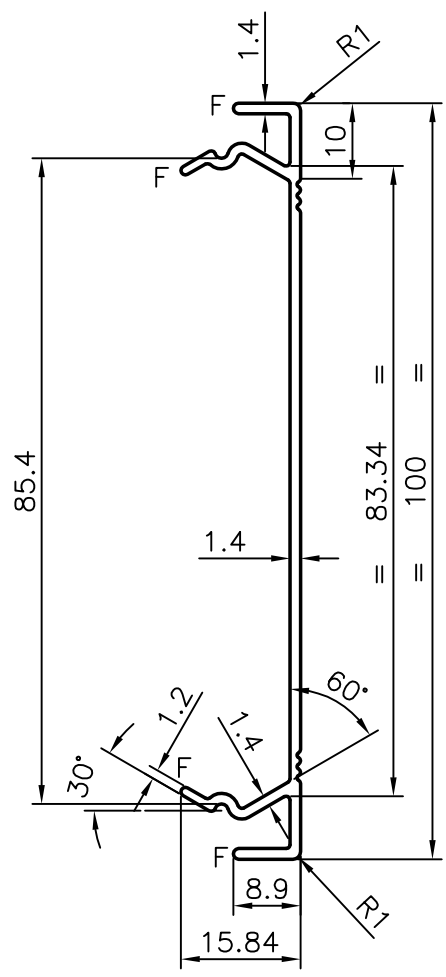
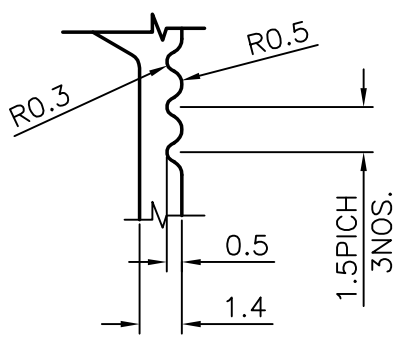
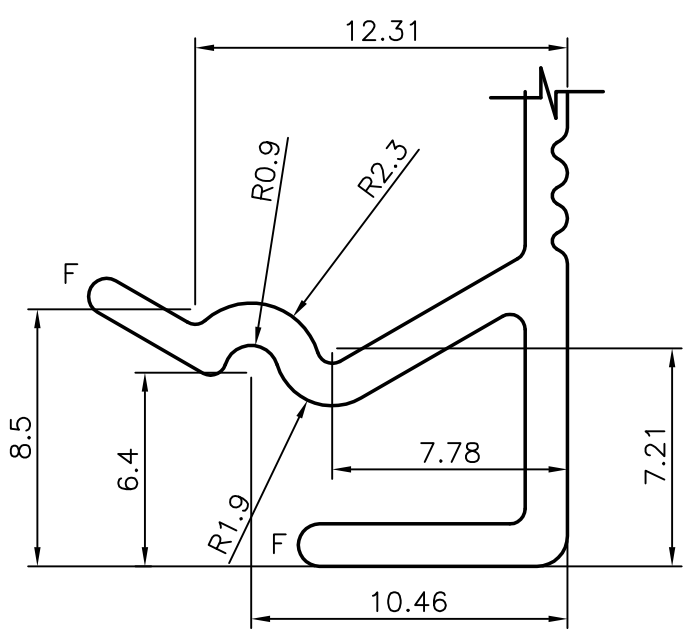

F= FULL RADIUS  
GENERAL WALL THICKNESS= 1.4  
MATCHING SECTION NO.= 22355, 22354



SYMBOL OF QUALITY  
AN ISO 9002 COMPANY

**JINDAL ALUMINIUM LTD.**  
BANGALORE-560073 (INDIA)

DRAWN	NAME	DATE
	D.K Shaw	05-09-03
CHECKED		
APPROVED		
SCALE	1:1	
AREA mm <sup>2</sup>	204.6	
PERIMETER mm.	297.6	
WEIGHT kg/m	0.552	
DRAWING No.	SECTION No.	
P-4409	-	
S1045	S1045	
22356	22356	

1. ALL DIMENSIONS ARE IN mm. 2. ROUND OFF ALL SHARP CORNERS WITH 0.50 mm. 3. TOLERANCES WILL BE AS PER IS: 3965-1981 UNLESS OTHERWISE SPECIFIED	
PARTY'S NAME	21st CENTURY OFFICES, BANGALORE
PARTY'S DRAWING No.	10206017
ALLOY & TEMPER	HE9, WP
DESCRIPTION	LID TCO-500