

P-4394

S1036

22357

② FOUR SCREW BOX ADDED.
AS PER PARTY'S REQUIREMENT

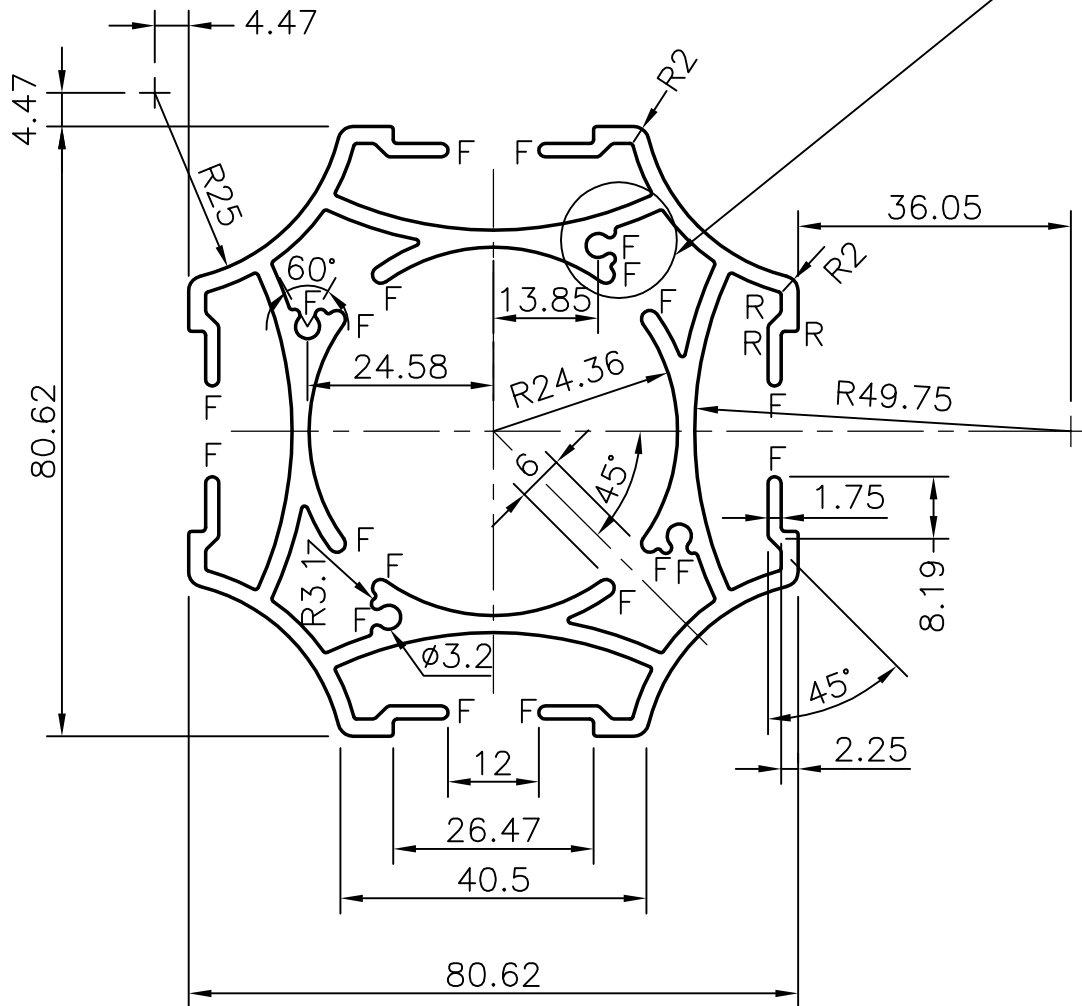

F = FULL RADIUS (24)

R = 0.5 RADIUS

GENERAL WALL THICKNESS = 2.25



SYMBOL OF QUALITY
AN ISO 9002 COMPANY

JINDAL ALUMINIUM LTD.
BANGALORE-560073 (INDIA)

	NAME	DATE
DRAWN	MALINGAPPA	21-10-2003
CHECKED		
APPROVED		

1. ALL DIMENSIONS ARE IN mm.
2. ROUND OFF ALL SHARP CORNERS WITH 0.40 mm.
3. TOLERANCES WILL BE AS PER IS: 6477-1983 UNLESS OTHERWISE SPECIFIED

SCALE	1:1
AREA mm ²	1127.2
PERIMETER mm.	588.1
WEIGHT kg/m	3.043

PARTY'S NAME	21 st CENTURY OFFICES, BANGALORE
PARTY'S DRAWING No.	10205914
ALLOY & TEMPER	HE9 WP
DESCRIPTION	CIRCULAR POST TCO-500

DRAWING No.	SECTION No.
P-4394	-
S1036-ISSUE-2	S1036-ISSUE-2
22357	22357