

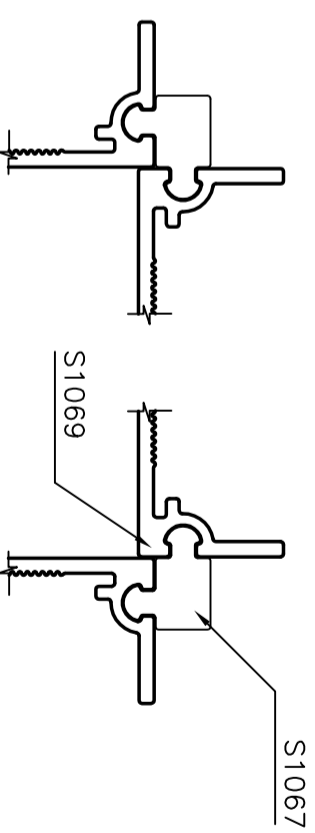

P-4462
S1069
22360

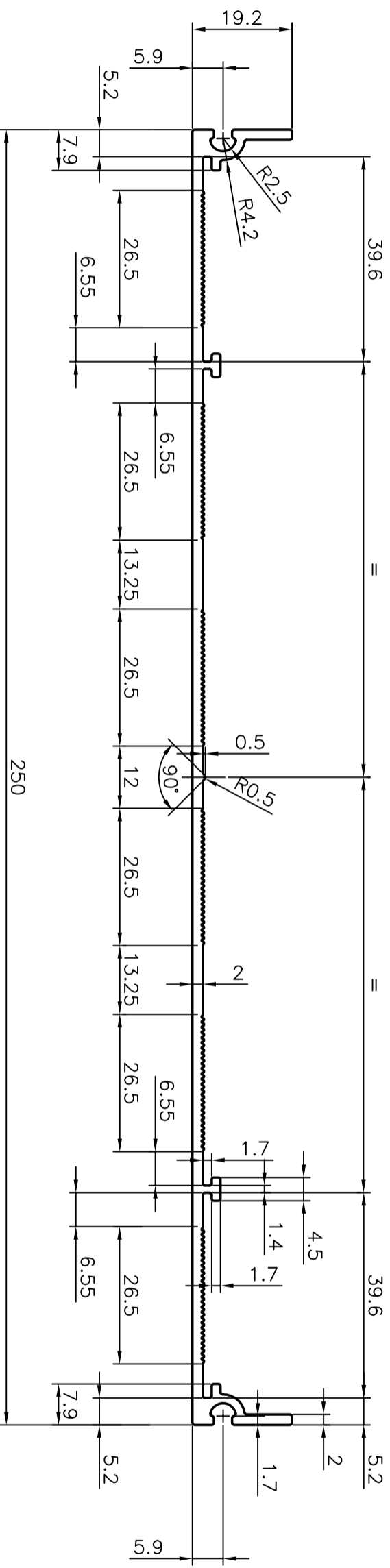

MATCHING SECTION NO. S1067

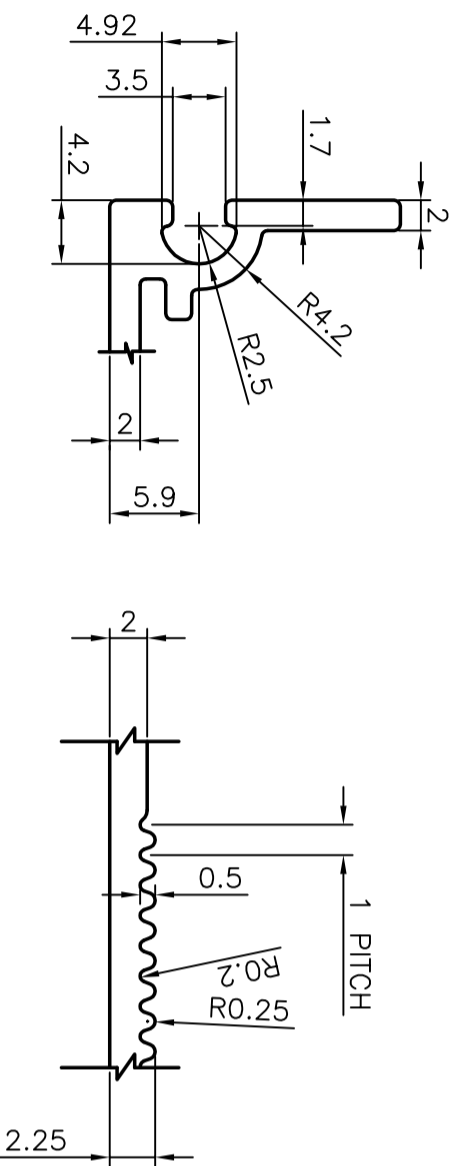

 SYMBOL OF QUALITY AN ISO 9002 COMPANY	JINDAL ALUMINIUM LTD. BANGALORE-560073 (INDIA)		NAME	DATE
	1. ALL DIMENSIONS ARE IN mm. 2. ROUND OFF ALL SHARP CORNERS WITH 0.40 mm. 3. TOLERANCES WILL BE AS PER IS: 3965-1981 UNLESS OTHERWISE SPECIFIED		DRAWN	malingappa
PARTY'S NAME	UNITED INSULATION, MUMBAI		CHECKED	
PARTY'S DRAWING No.	AS PER E-MAIL DRAWING (UI-ALUM SEC-7)		APPROVED	
ALLOY & TEMPER	HE9 WP		SCALE	1:1
DESCRIPTION	AXIOM 250mm		AREA mm ²	619.7
			PERIMETER mm.	699.2
			WEIGHT kg/m	1.673
			DRAWING No.	SECTION No.
			P-4462	-
			S1069	S1069
			22360	22360