

P-4675
X307
22367

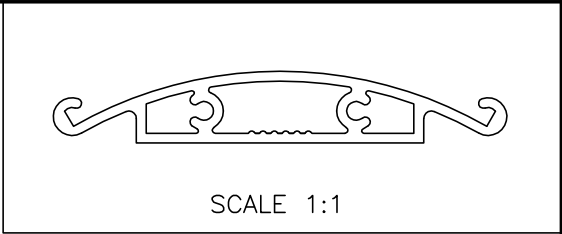

DETAIL "A"
SCALE 4:1

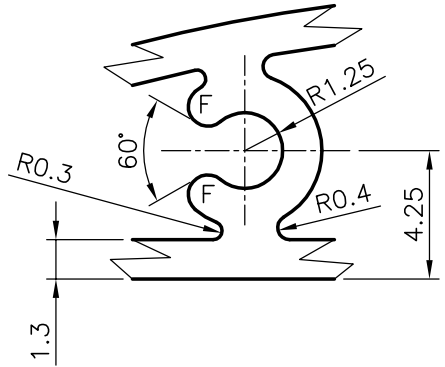

DETAIL "B"
SCALE 4:1

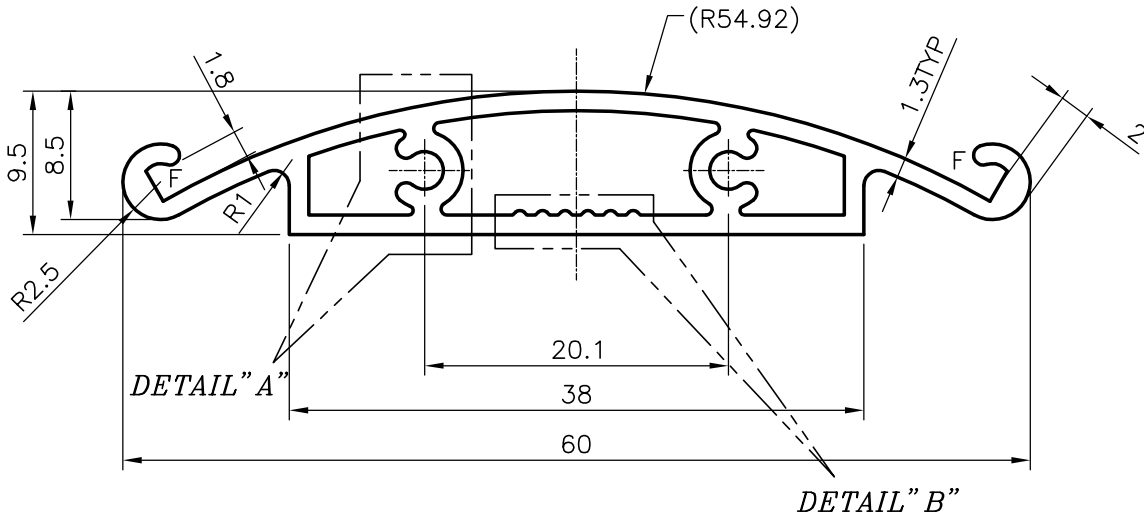
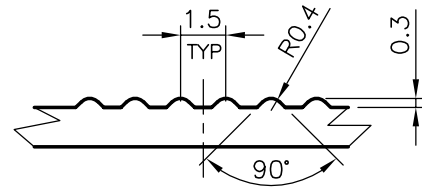

GENERAL WALL THICKNESS = 1.30mm
F = FULL RADIUS (6 PLACES)

 SYMBOL OF QUALITY AN ISO 9002 COMPANY	JINDAL ALUMINIUM LTD. BANGALORE-560073 (INDIA)	NAME		DATE
		DRAWN	RAGHAVENDRA	29-01-2004
1. ALL DIMENSIONS ARE IN mm. 2. ROUND OFF ALL SHARP CORNERS WITH 0.40 mm. 3. TOLERANCES WILL BE AS PER IS:6477-1983 UNLESS OTHERWISE SPECIFIED		CHECKED		
		APPROVED		
PARTY'S NAME RAJ INTERIOR DESIGNERS & ANODISERS., BANGALORE		SCALE		2:1
		AREA mm ²		184.736
PARTY'S DRAWING No. AS PER SAMPLE		PERIMETER mm.		150.403
		WEIGHT kg/m		0.499
ALLOY & TEMPER HE9 WP		DRAWING No.		SECTION No.
		P-4675		-
DESCRIPTION FURNITURE SECTION		X307		X307
		22367		22367