

P-5748-2

S1564

22383

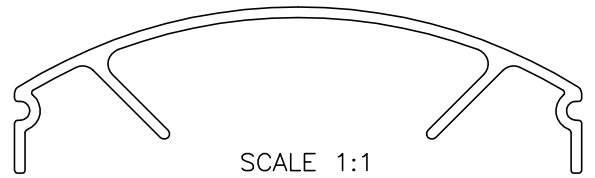

SCALE 1:1

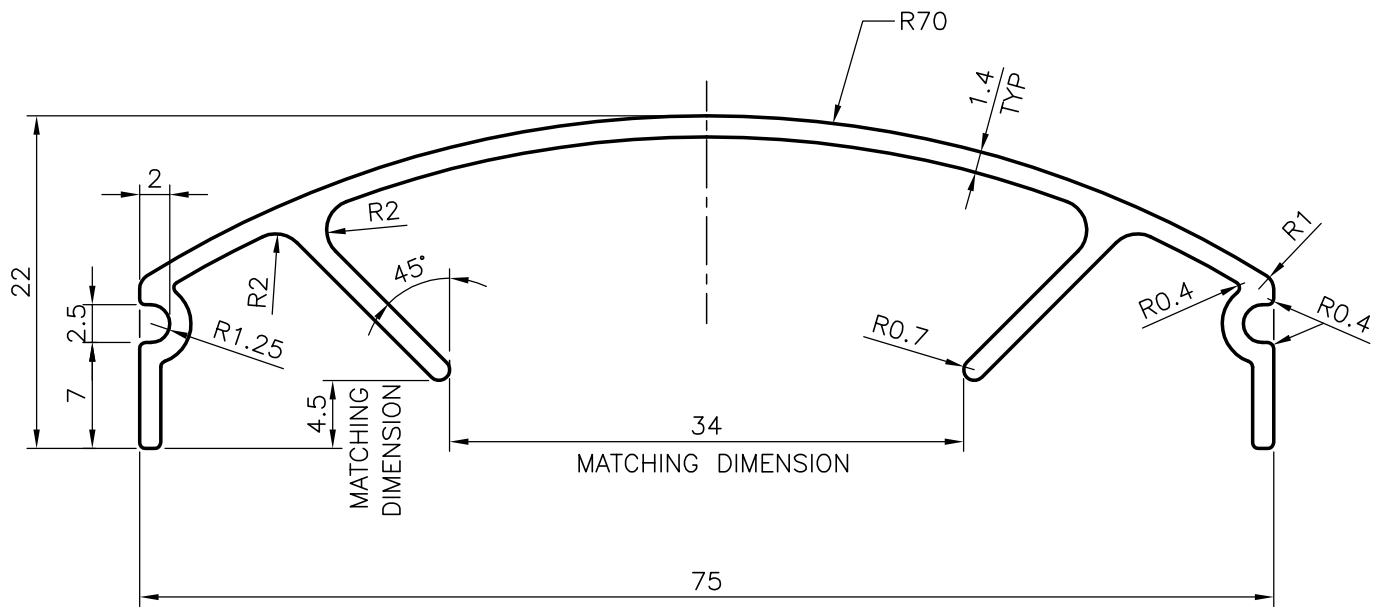

SECTION SHOULD MATCH WITH PARTY'S PLASTIC SAMPLE

GENERAL WALL THICKNESS = 1.40mm



SYMBOL OF QUALITY
AN ISO 9001 COMPANY

JINDAL ALUMINIUM LTD.
BANGALORE-560073 (INDIA)

	NAME	DATE
DRAWN	RAGHAVENDRA	06-08-2005
CHECKED		
APPROVED		

1. ALL DIMENSIONS ARE IN mm.
2. ROUND OFF ALL SHARP CORNERS WITH 0.40 mm.
3. TOLERANCES WILL BE AS PER IS:3965-1981 UNLESS OTHERWISE SPECIFIED

SCALE	2:1
AREA mm ²	189.775
PERIMETER mm.	257.756
WEIGHT kg/m	0.512

PARTY'S NAME	SUMAN FURNITURES CO., BANGALORE
PARTY'S DRAWING No.	AS PER SAMPLE & AS PER REQUIREMENT
ALLOY & TEMPER	HE9 WP
DESCRIPTION	FURNITURE SECTION

DRAWING No.	SECTION No.
P-5748-2	-
S1564	S1564
22383	22383