

P-5193

S1387

22386

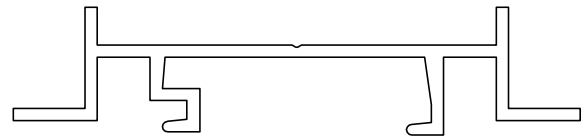

SCALE 1:1

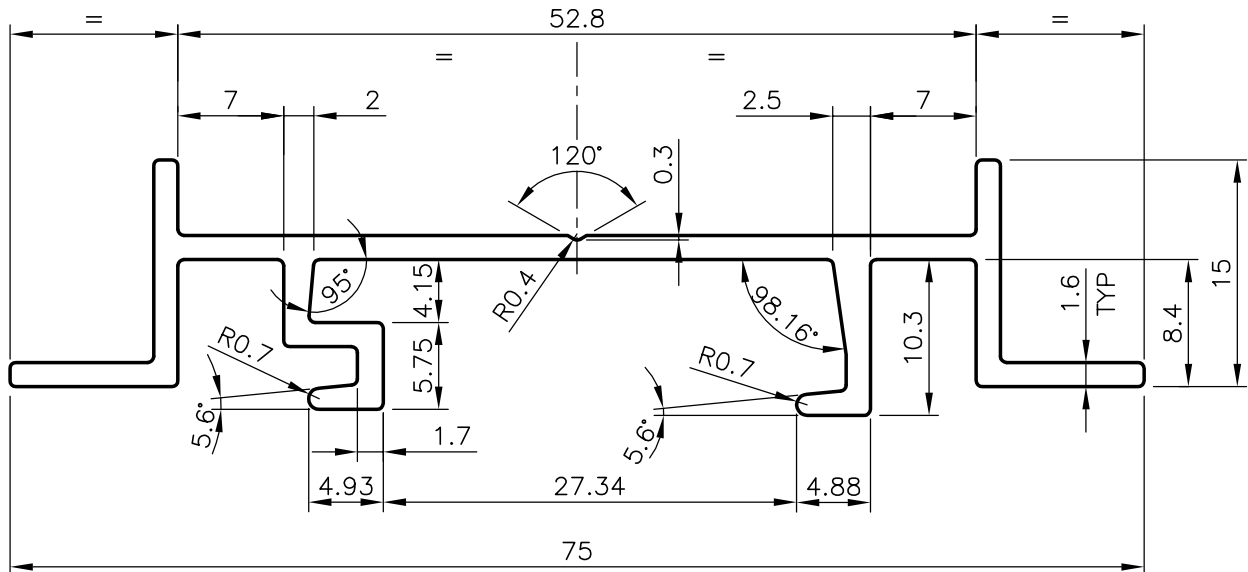

GENERAL WALL THICKNESS = 1.60mm UNLESS OTHERWISE SPECIFIED



SYMBOL OF QUALITY
AN ISO 9001 COMPANY

JINDAL ALUMINIUM LTD.
BANGALORE-560073 (INDIA)

	NAME	DATE
DRAWN	RAJESH	17-12-2004
CHECKED		
APPROVED		
SCALE		2:1
AREA mm ²		216.406
PERIMETER mm.		262.703
WEIGHT kg/m		0.584

1. ALL DIMENSIONS ARE IN mm.
2. ROUND OFF ALL SHARP CORNERS WITH 0.40 mm.
3. TOLERANCES WILL BE AS PER IS:3965-1981 UNLESS OTHERWISE SPECIFIED

PARTY'S NAME	INNOVATIVE OFFICE SOLUTIONS, BANGALORE	DRAWING No.	SECTION No.
PARTY'S DRAWING No.	AS PER DRAWING	P-5193	-
ALLOY & TEMPER	HE9 WP	S1387	S1387
DESCRIPTION	FURNITURE SECTION	22386	22386