

P-6001
X488
22400

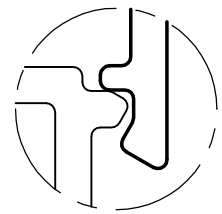

DETAIL-A
SCALE 4:1

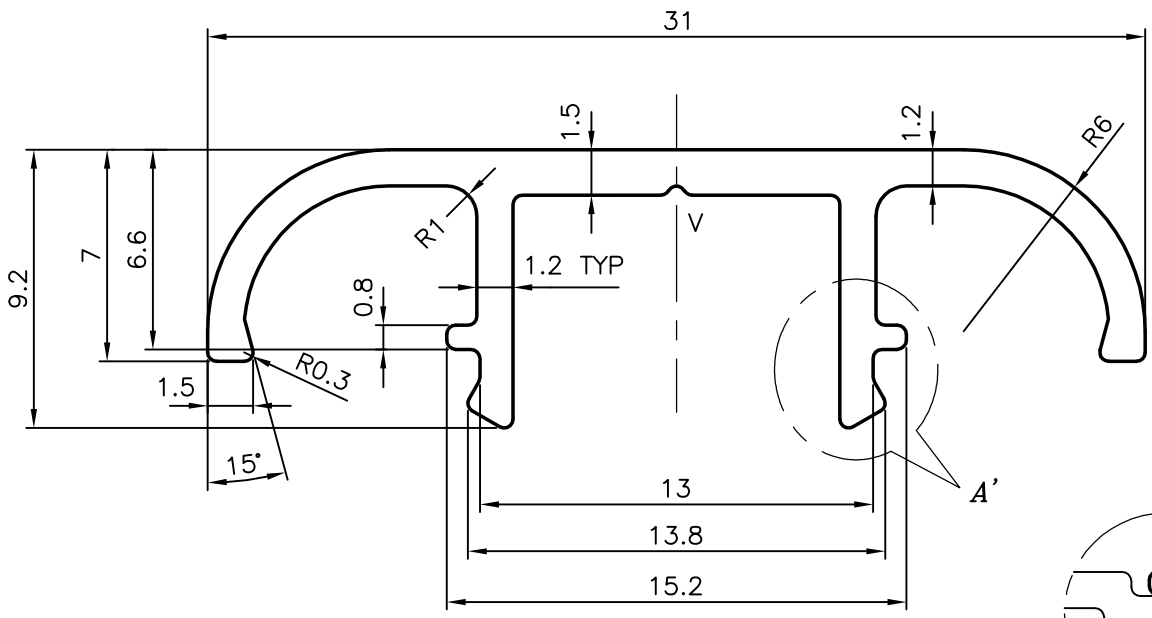
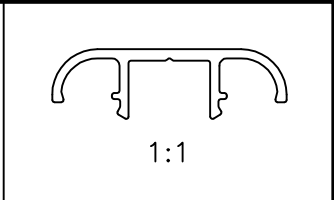
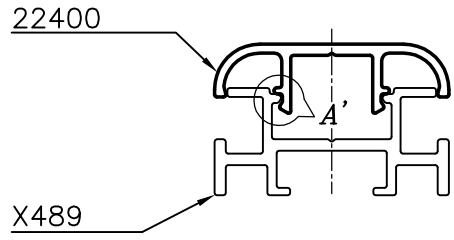
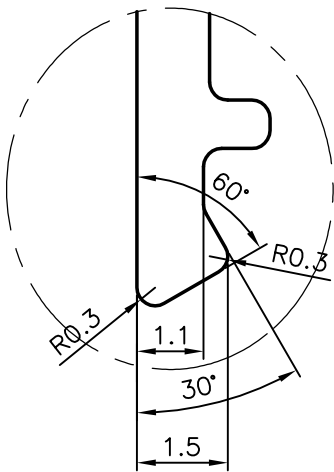

DETAIL-A
SCALE: -8:1

GENERAL WALL THICKNESS = 1.2 mm
 V = VEE GROOVE 0.3xR0.3 (1 PLACE)
 UNSPECIFIED CORNER RADIUS SHOULD BE 0.3 mm



JINDAL ALUMINIUM LTD.
 BANGALORE-560073 (INDIA)

	NAME	DATE
DRAWN	MALINGAPPA	29-11-2005
CHECKED		
APPROVED		
SCALE		4:1
AREA mm ²		69.985
PERIMETER mm.		111.54
WEIGHT kg/m		0.189
DRAWING No.	SECTION No.	
P-6001	-	
X488	X488	
22400	22400	

1. ALL DIMENSIONS ARE IN mm. 2. ROUND OFF ALL SHARP CORNERS WITH 0.40 mm. 3. TOLERANCES WILL BE AS PER IS:3965-1981 UNLESS OTHERWISE SPECIFIED	
PARTY'S NAME	WIPRO CONSUMER CARE & LIGHTING, BANGALORE
PARTY'S DRAWING No.	VBA D 0005
ALLOY & TEMPER	HE9 WP
DESCRIPTION	TOP CAP 30 mm