

P-5645

S1532

22402

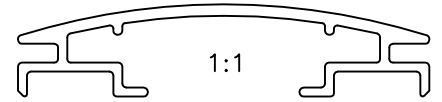

1:1

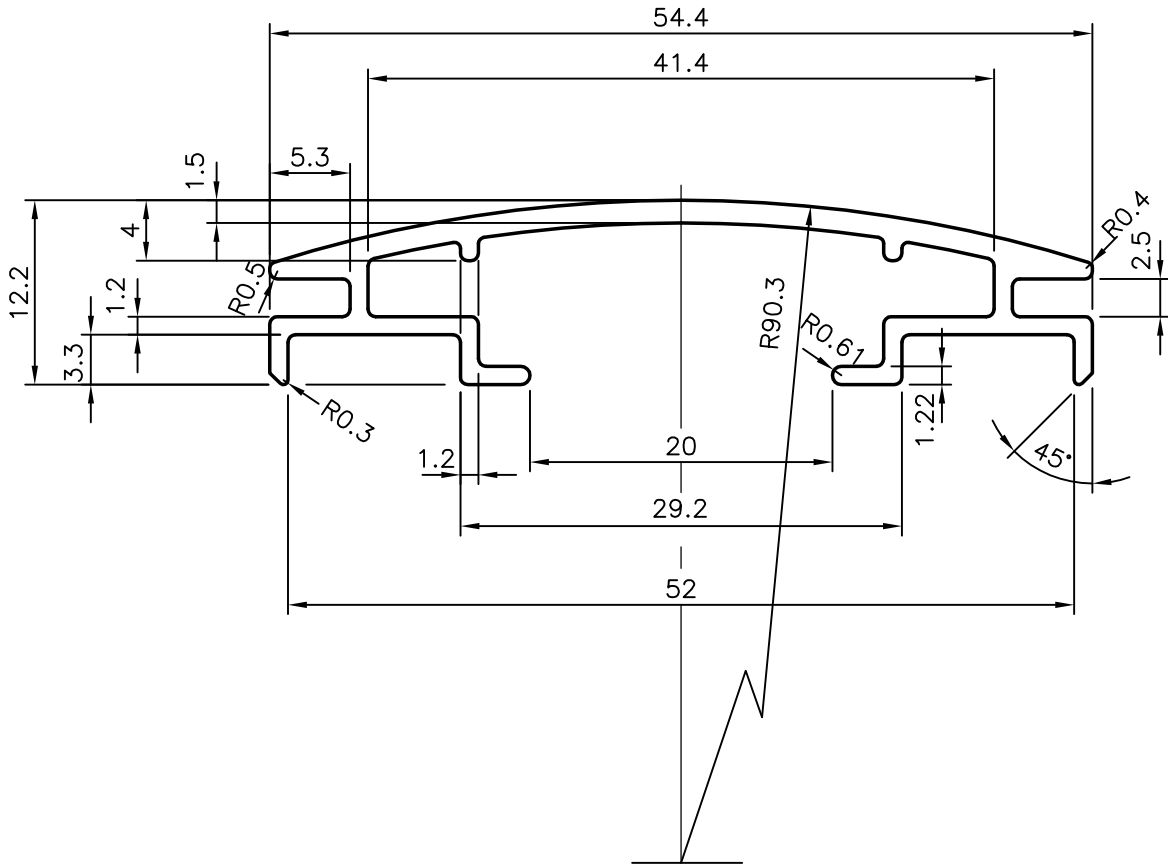

SYMBOL OF QUALITY  
AN ISO 9002 COMPANY

**JINDAL ALUMINIUM LTD.**  
BANGALORE-560073 (INDIA)

	NAME	DATE
DRAWN	MALINGAPPA	07-07-2005
CHECKED		
APPROVED		

1. ALL DIMENSIONS ARE IN mm.
2. ROUND OFF ALL SHARP CORNERS WITH 0.40 mm.
3. TOLERANCES WILL BE AS PER IS:3965-1981 UNLESS OTHERWISE SPECIFIED

SCALE	2:1
AREA mm <sup>2</sup>	153.745
PERIMETER mm.	216.744
WEIGHT kg/m	0.415

PARTY'S NAME	FEATHERLITE OFFICE SYSTEMS PVT. LTD., BANGALORE
PARTY'S DRAWING No.	50 TOPTRIM-V2
ALLOY & TEMPER	HE9 WP
DESCRIPTION	FURNITURE SECTION

DRAWING No.	SECTION No.
P-5645	-
S1532	S1532
22402	22402