

P-5898
S1614
X569
22427

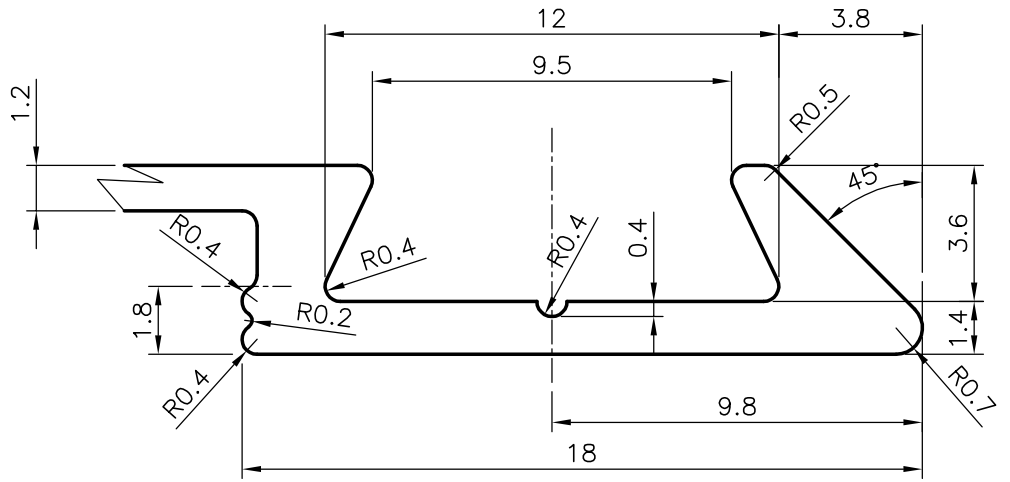

DETAIL "A"
SCALE 5:1

DETAIL "B"
SCALE 5:1

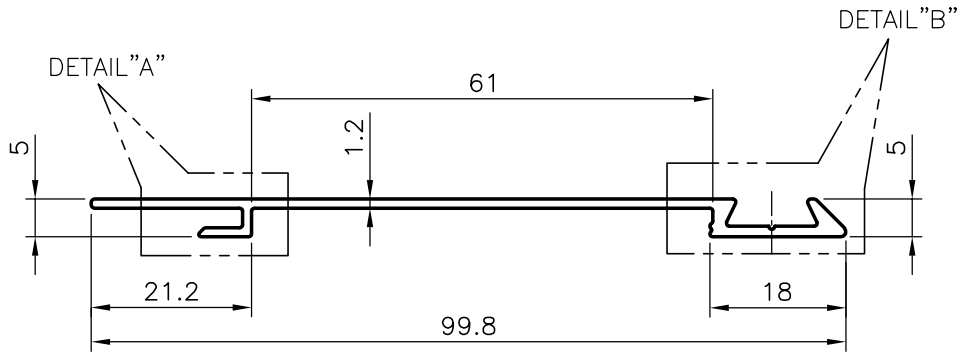
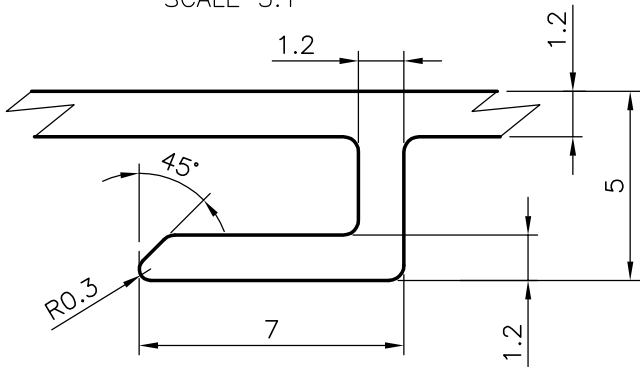

COMPONENT SHOULD BE FREE FROM BURRS & SHARP EDGES

 SYMBOL OF QUALITY AN ISO 9001 COMPANY	JINDAL ALUMINIUM LTD. BANGALORE-560073 (INDIA)	NAME	DATE
		DRAWN	RAGHAVENDRA 03-10-2005
		CHECKED	
1. ALL DIMENSIONS ARE IN mm. 2. ROUND OFF ALL SHARP CORNERS WITH 0.40 mm. 3. TOLERANCES WILL BE AS PER IS:3965-1981 UNLESS OTHERWISE SPECIFIED		APPROVED	
PARTY'S NAME		UNITED INSULATION., MUMBAI	
PARTY'S DRAWING No.		DRG-064	
ALLOY & TEMPER		HE9 WP	
DESCRIPTION		FURNITURE SECTION	
		SCALE	1:1
		AREA mm ²	151.306
		PERIMETER mm.	234.867
		WEIGHT kg/m	0.409
		DRAWING No.	SECTION No.
		P-5898	-
		S1614	S1614
		X569	X569
		22427	22427