

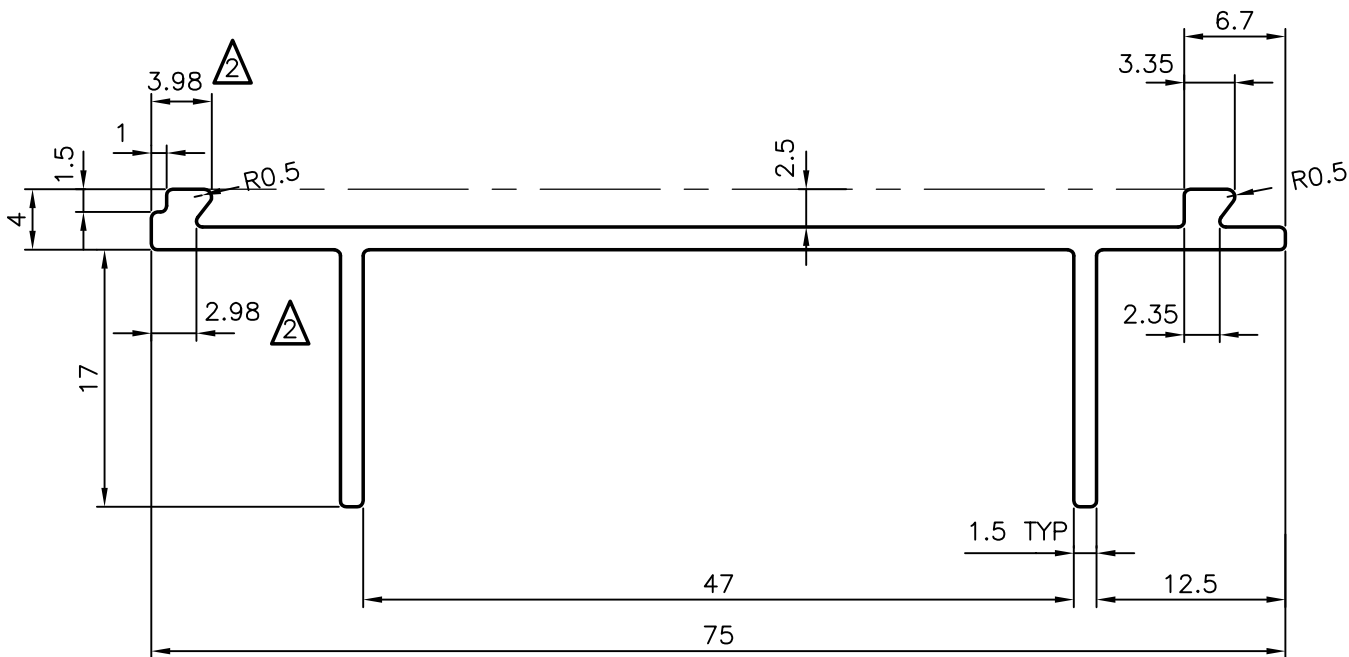

P-6159-1  
S1698  
22434

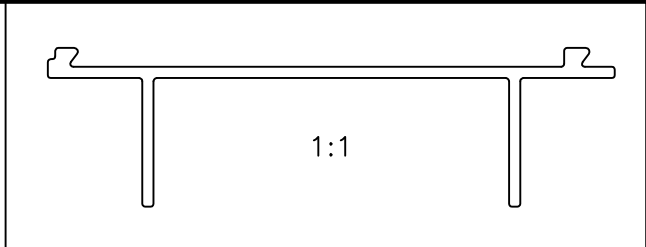

GENERAL WALL THICKNESS = 1.5 mm

ISSUE-2  $\triangle$  MARKED DIMENSION CHANGED FROM 3.35 TO 3.98 mm  
2.35 TO 2.98 mm

 SYMBOL OF QUALITY AN ISO 9001 COMPANY	<b>JINDAL ALUMINIUM LTD.</b> BANGALORE-560073 (INDIA)	NAME		DATE	
		DRAWN	MALINGAPPA	28-02-2006	
		CHECKED			
1. ALL DIMENSIONS ARE IN mm. 2. ROUND OFF ALL SHARP CORNERS WITH 0.40 mm. 3. TOLERANCES WILL BE AS PER IS:3965-1981 UNLESS OTHERWISE SPECIFIED		SCALE	2:1		
PARTY'S NAME		V2 MODULAR FURNITURE, BANGALORE		AREA mm <sup>2</sup>	177.786
		PARTY'S DRAWING No. AS PER DRAWING		PERIMETER mm.	230.119
ALLOY & TEMPER		HE9 WP		WEIGHT kg/m	0.480
		DESCRIPTION FURNITURE SECTION		DRAWING No.	SECTION No.
				P-6159-1	-
				S1698	S1698-ISSUE-2
				22434	22434