

P-6252-1
X555
22442

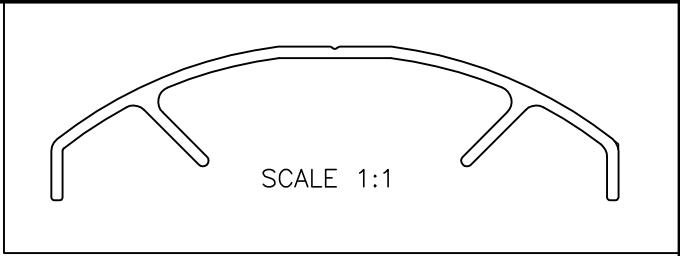

R = 2mm RADIUS (8 PLACES)  
 F = FULL RADIUS (2 PLACES)

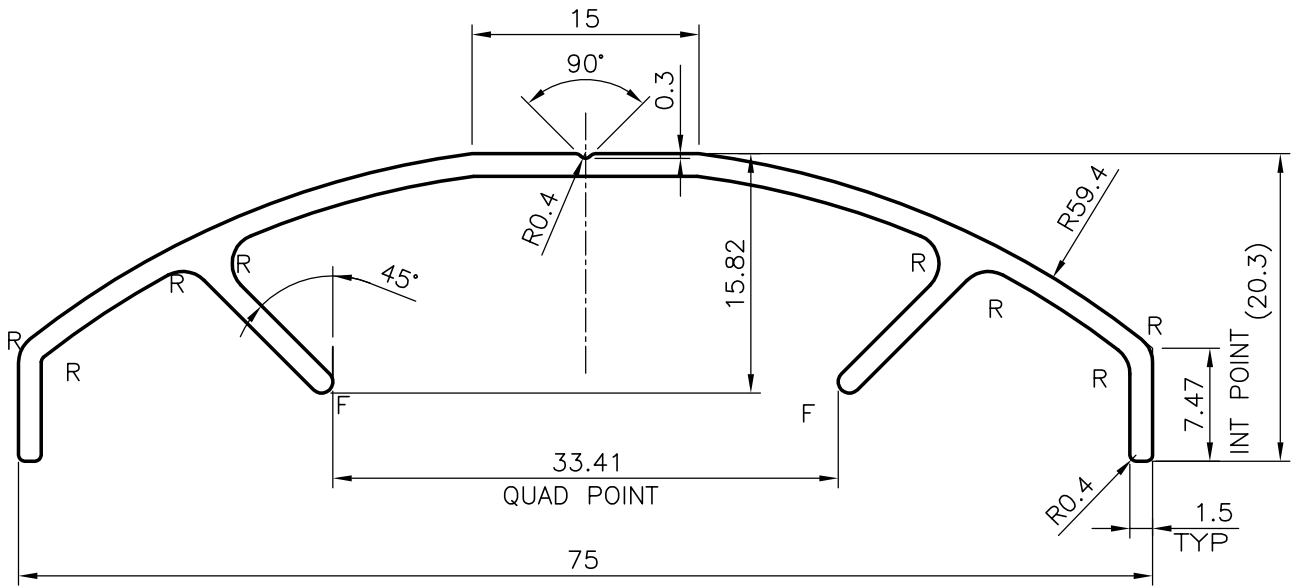

**JINDAL ALUMINIUM LTD.**  
 BANGALORE-560073 (INDIA)

	NAME	DATE
DRAWN	J.P.KAUSHIK	21-03-2006
CHECKED		
APPROVED		

1. ALL DIMENSIONS ARE IN mm.
2. ROUND OFF ALL SHARP CORNERS WITH 0.40 mm.
3. TOLERANCES WILL BE AS PER IS:3965-1981 UNLESS OTHERWISE SPECIFIED

SCALE	2:1
AREA mm <sup>2</sup>	180.898
PERIMETER mm.	231.941
WEIGHT kg/m	0.488

PARTY'S NAME	FRIENDS MODULAR ENGINEERS.,BANGALORE
PARTY'S DRAWING No.	AS PER SAMPLE
ALLOY & TEMPER	HE9 WP
DESCRIPTION	FURNITURE SECTION

DRAWING No.	SECTION No.
P-6252-1	-
X555	X555
22442	22442