

P-6639

S1848

22461

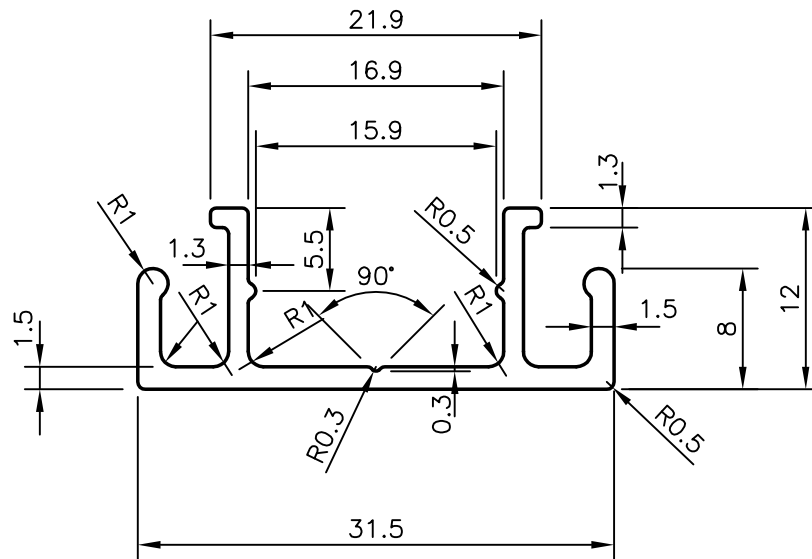
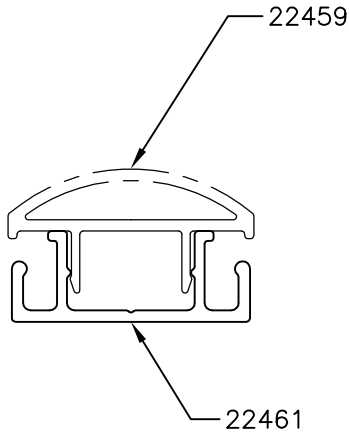

GENERAL WALL THICKNESS 1.50 (TYP)



SYMBOL OF QUALITY
AN ISO 9002 COMPANY

JINDAL ALUMINIUM LTD.
BANGALORE-560073 (INDIA)

	NAME	DATE
DRAWN	J.P.KAUSHIK	11-11-2006
CHECKED		
APPROVED		
SCALE		2:1
AREA mm ²		99.658
PERIMETER mm.		134.964
WEIGHT kg/m		0.269
DRAWING No.		SECTION No.
P-6639		-
S1848		S1848(ISSUE-2)
22461		22461

1. ALL DIMENSIONS ARE IN mm.
2. ROUND OFF ALL SHARP CORNERS WITH 0.40 mm.
3. TOLERANCES WILL BE AS PER IS:3965-1981 UNLESS OTHERWISE SPECIFIED

PARTY'S NAME	FORM DESIGN (INDIA) PVT. LTD., MUMBAI
PARTY'S DRAWING No.	AS PER DRAWING
ALLOY & TEMPER	HE9 WP
DESCRIPTION	MISC. SECTION