

P-7007
S1946
22476

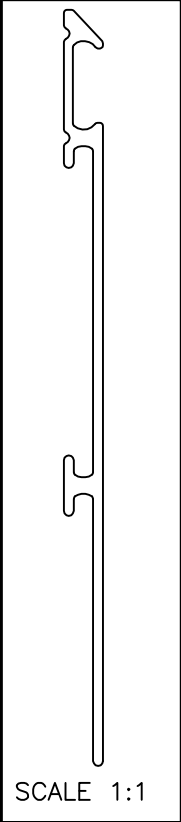

THIS CLIP SHOULD NOT COME OUT

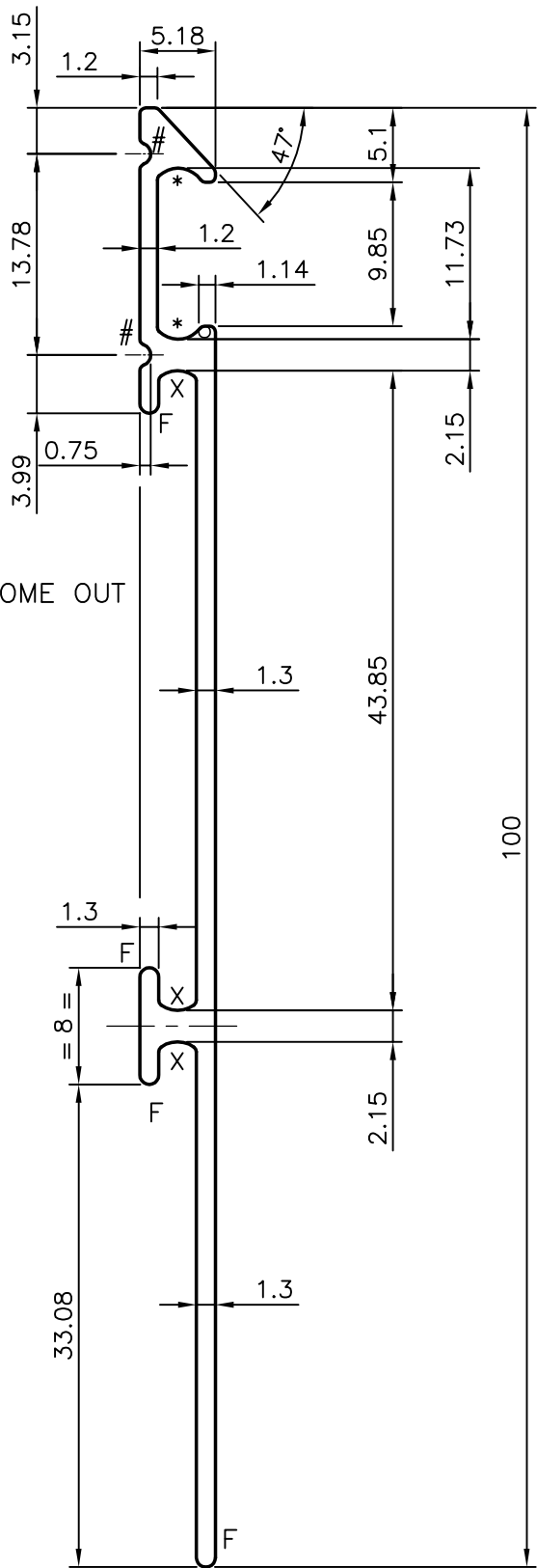
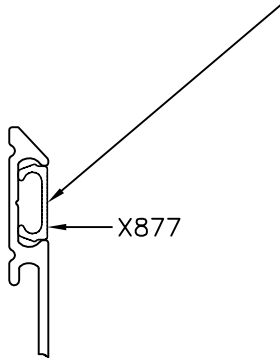

NOTE:-

1. F = FULL RADIUS (4 PLACES)
2. * = R1.87 mm (2 PLACES)
3. X = R1.91 mm (3 PLACES)
4. # = R0.75 mm 92 PLACES)

 SYMBOL OF QUALITY AN ISO 9001 COMPANY	JINDAL ALUMINIUM LTD. BANGALORE-560073 (INDIA)	NAME		DATE
		DRAWN	PRASANN.H	03-02-2007
1. ALL DIMENSIONS ARE IN mm. 2. ROUND OFF ALL SHARP CORNERS WITH 0.4 mm. 3. TOLERANCES WILL BE AS PERIS:3965-1981 UNLESS OTHERWISE SPECIFIED		CHECKED		
		APPROVED		
PARTY'S NAME ENSEMBLE FURNITURE SOLUTIONS(P)LTD., B'LORE		SCALE		2:1
		AREA mm ²		166.18
PARTY'S DRAWING No. EFSPL/PRESTIGE/AL SKT R1-22c		PERIMETER mm.		238.834
		WEIGHT kg/m		0.449
ALLOY & TEMPER HE9 WP		DRAWING No.		SECTION No.
		P-7007		-
DESCRIPTION FURNITURE SECTION		S1946		S1946
		22476		22476