

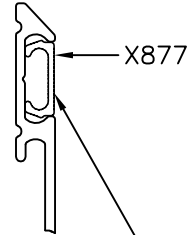

P-7008
S1947
22477

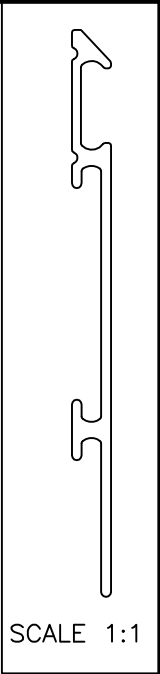
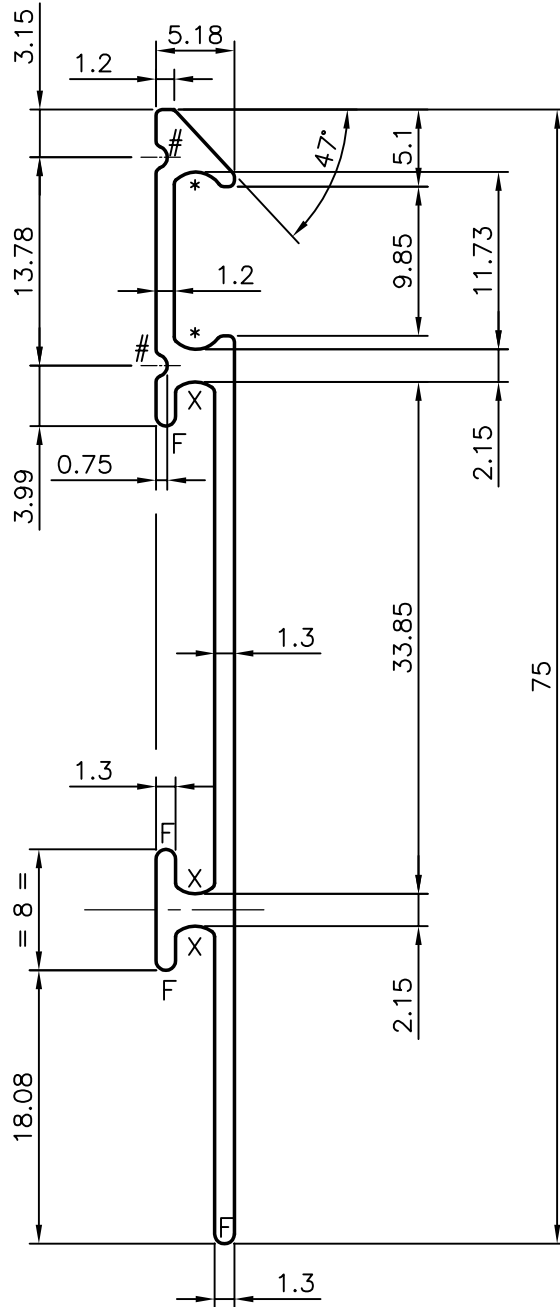

THIS CLIP SHOULD NOT COME OUT

- NOTE:-
1. F = FULL RADIUS (4 PLACES)
 2. * = R1.87 mm (2 PLACES)
 3. X = R1.91 mm (3 PLACES)
 4. # = R0.75 mm (2 PLACES)

 SYMBOL OF QUALITY AN ISO 9001 COMPANY	JINDAL ALUMINIUM LTD. BANGALORE-560073 (INDIA)	DRAWN	NAME	DATE
		CHECKED	PRASANN.H	03-02-2007
1. ALL DIMENSIONS ARE IN mm. 2. ROUND OFF ALL SHARP CORNERS WITH 0.4 mm. 3. TOLERANCES WILL BE AS PERIS:3965-1981 UNLESS OTHERWISE SPECIFIED		APPROVED		
		SCALE	2:1	
PARTY'S NAME ENSEMBLE FURNITURE SOLUTIONS(P)LTD., B'LORE		AREA	mm ² 133.68	
		PERIMETER	mm. 188.834	
PARTY'S DRAWING No. EFSPL/PRESTIGE/AL SKT R1-22a		WEIGHT	kg/m 0.361	
		DRAWING No.	SECTION No.	
ALLOY & TEMPER HE9 WP		P-7008	-	
		S1947	S1947	
DESCRIPTION FURNITURE SECTION		22477	22477	