

P-7042
S1959
22478

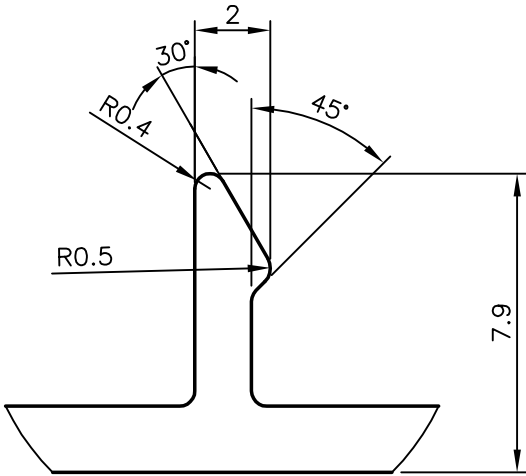

DETAIL OF "A"
SCALE 5:1

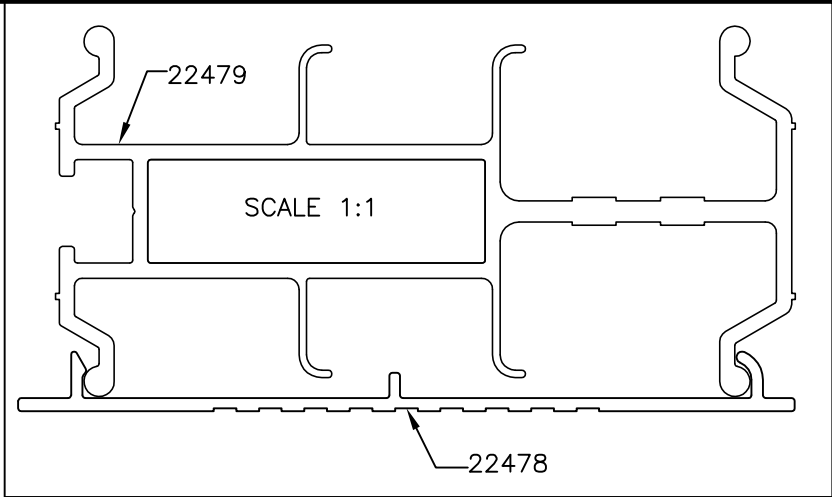
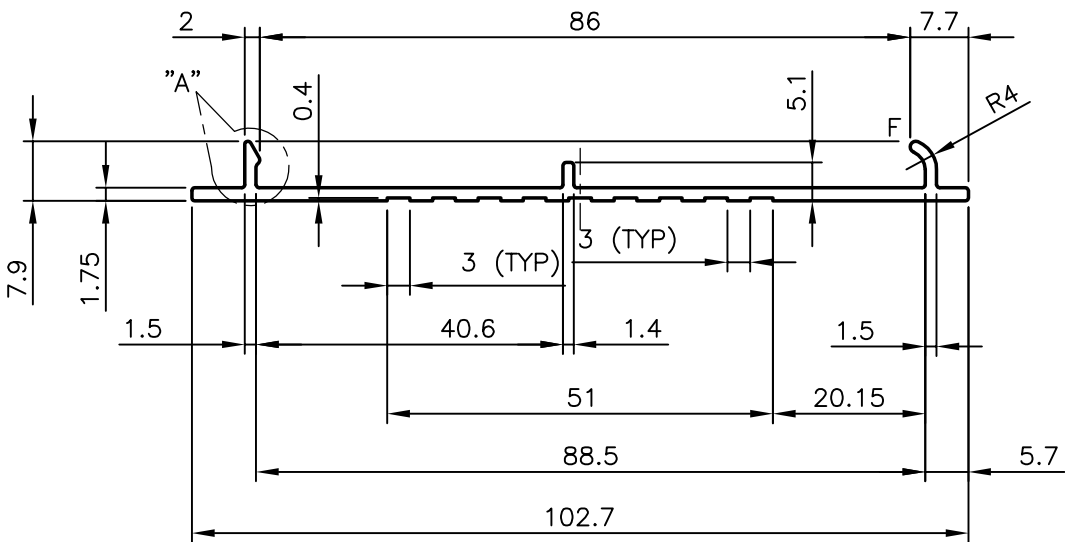

NOTE:-

1. F = FULL RADIUS (1 PLACES)

 SYMBOL OF QUALITY AN ISO 9001 COMPANY	JINDAL ALUMINIUM LTD. BANGALORE-560073 (INDIA)	NAME		DATE
		DRAWN	PRASANN.H	02-03-2007
1. ALL DIMENSIONS ARE IN mm. 2. ROUND OFF ALL SHARP CORNERS WITH 0.40 mm. 3. TOLERANCES WILL BE AS PER IS:3965-1981 UNLESS OTHERWISE SPECIFIED		CHECKED		
		APPROVED		
PARTY'S NAME WUDLIN INTERIOR SYSTEMS, COCHIN		SCALE		1:1
		AREA mm ²		192.868
PARTY'S DRAWING No. AS PER SAMPLE		PERIMETER mm.		245.785
		WEIGHT kg/m		0.521
ALLOY & TEMPER HE9 WP		DRAWING No.		SECTION No.
		P-7042		-
DESCRIPTION MISC. PROFILE		S1959		S1959
		22478		22478