

P-7043

S1960

22479

MATCHING SECTIONS

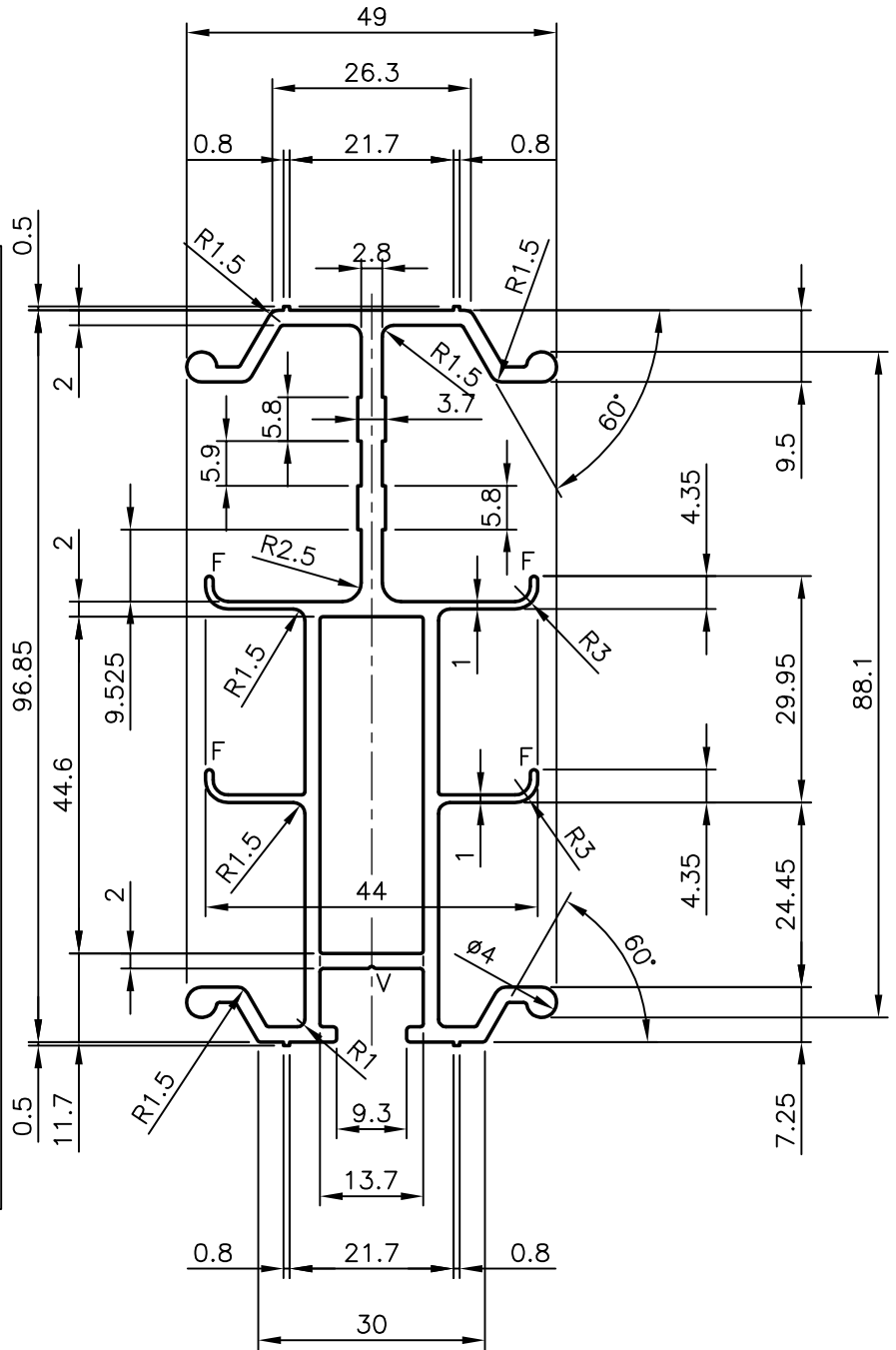
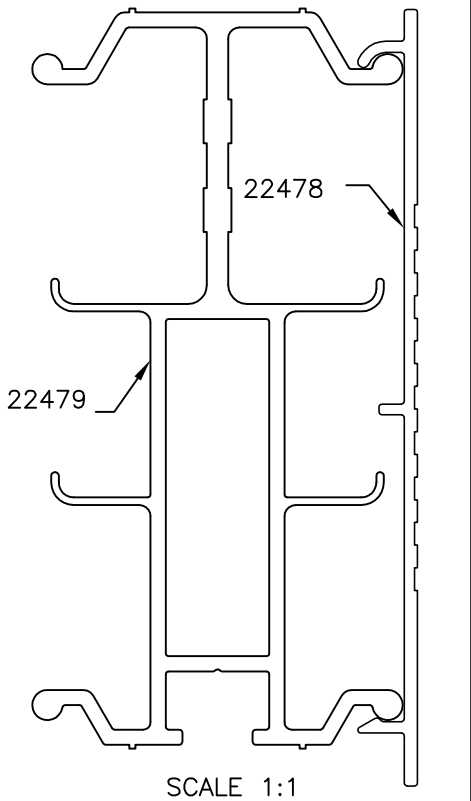

NOTE:-

- 1. UNSPECIFIED WALL THICKNESS = 2.0 mm
- 2. F = FULL RADIUS (4 PLACES)
- 3. V = 0.3x90° (1 PLACE)



SYMBOL OF QUALITY
AN ISO 9001 COMPANY

JINDAL ALUMINIUM LTD.
BANGALORE-560073 (INDIA)

	NAME	DATE
DRAWN	PRASANN.H	02-03-2007
CHECKED		
APPROVED		
SCALE	1:1	
AREA mm ²	689.654	
PERIMETER mm.	566.53	
WEIGHT kg/m	1.862	
DRAWING No.	SECTION No.	
P-7043	-	
S1960	S1960	
22479	22479	

- 1. ALL DIMENSIONS ARE IN mm.
- 2. ROUND OFF ALL SHARP CORNERS WITH 0.40 mm.
- 3. TOLERANCES WILL BE AS PER IS:6477-1983 UNLESS OTHERWISE SPECIFIED

PARTY'S NAME	WUDLIN INTERIOR SYSTEMS, COCHIN
PARTY'S DRAWING No.	AS PER SAMPLE
ALLOY & TEMPER	HE9 WP
DESCRIPTION	MISC. PROFILE