

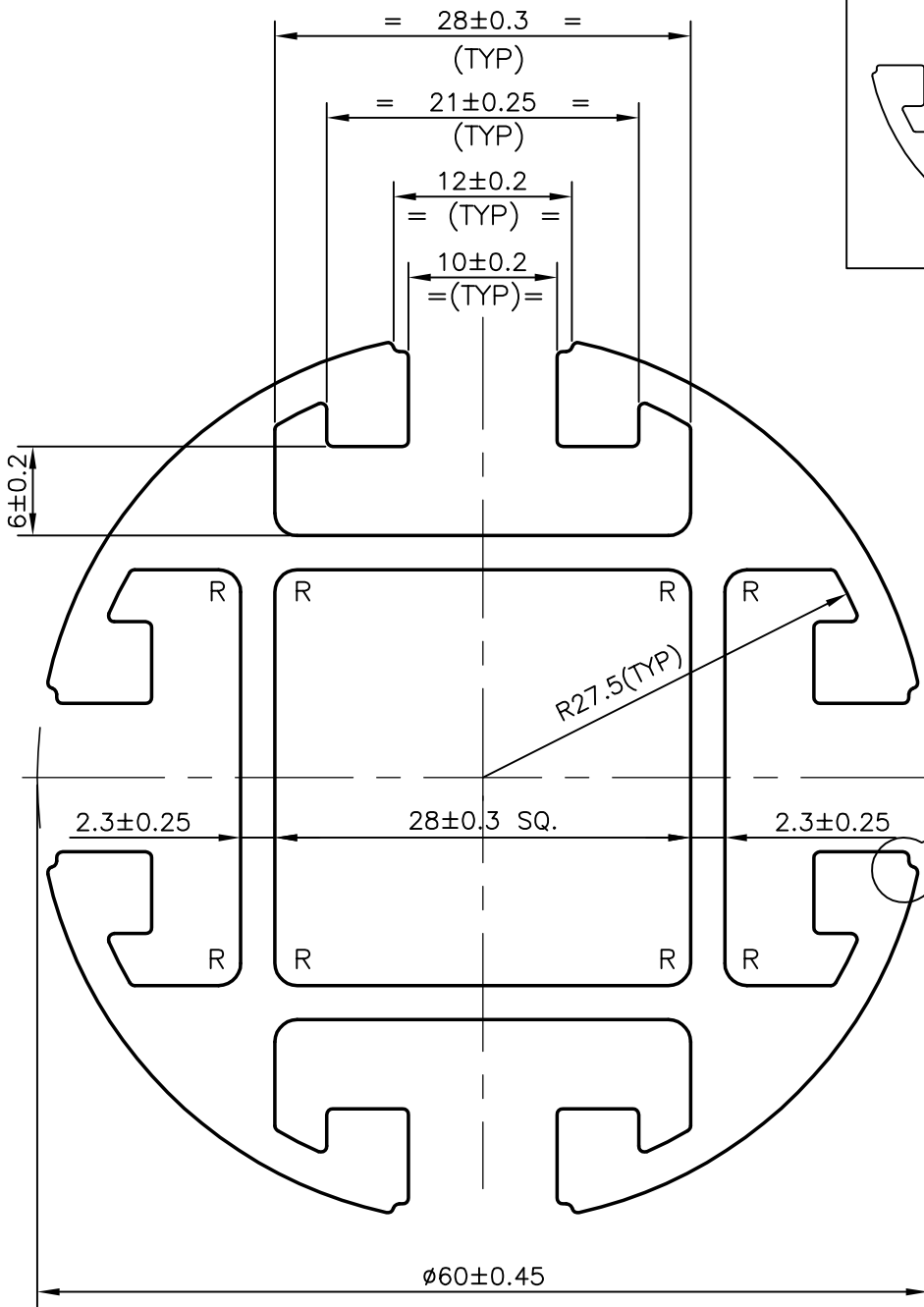

P-7446
S2055
22489

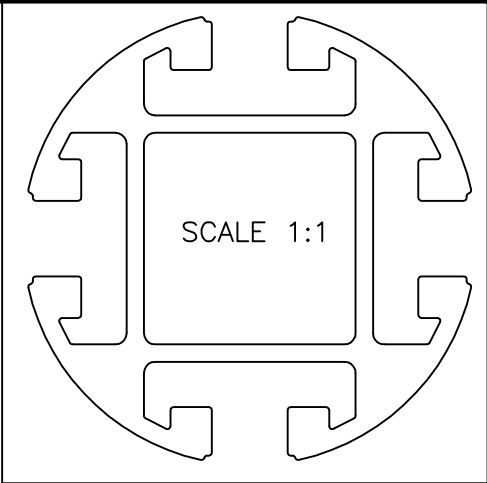

DETAIL OF "A"
SCALE 5:1

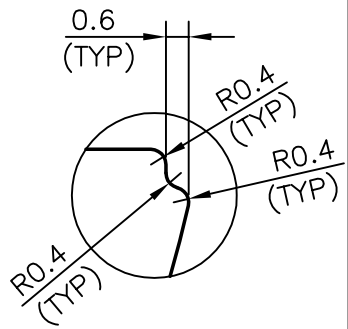

R = R1.50 mm (8 PLACES)

 SYMBOL OF QUALITY AN ISO 9001 COMPANY	JINDAL ALUMINIUM LTD. BANGALORE-560073 (INDIA)	DRAWN PRASANN.H 07-08-2007	NAME PRASANN.H DATE 07-08-2007
		CHECKED APPROVED	SCALE 2:1 AREA mm ² 1003.918 PERIMETER mm. 459.759 WEIGHT kg/m 2.711
1. ALL DIMENSIONS ARE IN mm. 2. ROUND OFF ALL SHARP CORNERS WITH 0.40 mm. 3. TOLERANCES WILL BE AS PER IS:6477-1983 UNLESS OTHERWISE SPECIFIED		DRAWING No. P-7446 S2055 22489	SECTION No. - S2055 22489
PARTY'S NAME EYE PHOTONICS (INDIA) PVT. LTD., PONDICHERY	PARTY'S DRAWING No. AS PER DRAWING	DESCRIPTION CHAIR UNIT STAND-MISC. TUBE	