

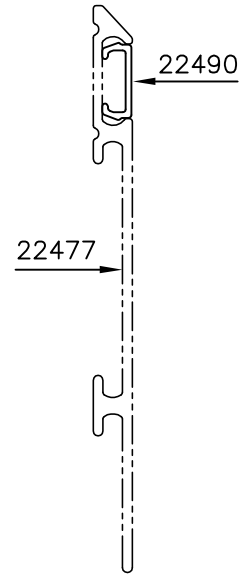

P-9538

22490

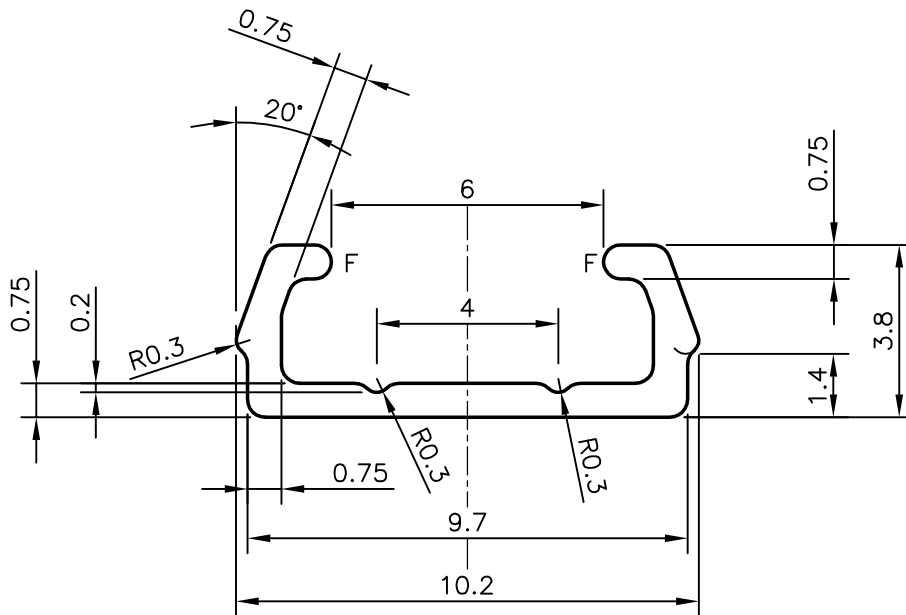
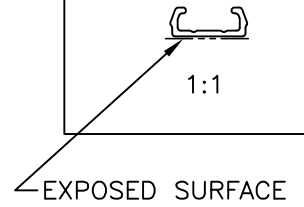

F = FULL RADIUS (2 PLACES)

 SYMBOL OF QUALITY AN ISO 9001 COMPANY	JINDAL ALUMINIUM LTD. BANGALORE-560073 (INDIA)	NAME	DATE
		DRAWN	J.P.KAUSHIK 26-10-2009
1. ALL DIMENSIONS ARE IN mm. 2. ROUND OFF ALL SHARP CORNERS WITH 0.40 mm. 3. TOLERANCES WILL BE AS PER IS:3965-1981 UNLESS OTHERWISE SPECIFIED		CHECKED	
		APPROVED	
PARTY'S NAME GENERAL CATEGORY, DELHI MARKET		SCALE	6:1
		AREA mm ²	13.046
PARTY'S DRAWING No. AS PER SKETCH		PERIMETER mm.	35.066
		WEIGHT kg/m	0.035
ALLOY & TEMPER HE9 WP		DRAWING No.	SECTION No.
		P-9538	-
DESCRIPTION FURNITURE SECTION		22490	22490