

P-7481

X716

22492

DETAIL OF "A"
SCALE 3:1
(13)

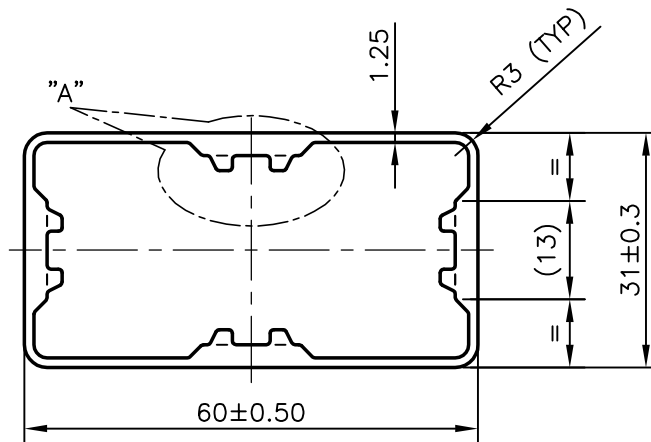
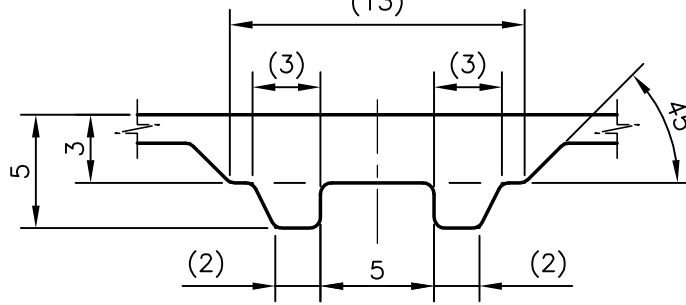

NOTE:-

1. GENERAL WALL THICKNESS = 1.25 mm
2. UNSPECIFIED RADIUS = 0.5 mm
3. DEBURR ALL THE SHARP EDGES AND CORNERS



SYMBOL OF QUALITY
AN ISO 9001 COMPANY

JINDAL ALUMINIUM LTD.
BANGALORE-560073 (INDIA)

	NAME	DATE
DRAWN	PRASANN.H	31-08-2007
CHECKED		
APPROVED		
SCALE		1:1
AREA mm ²		359.403
PERIMETER mm.		176.85
WEIGHT kg/m		0.970
DRAWING No.		SECTION No.
P-7481		-
X716		X716
22492		22492

1. ALL DIMENSIONS ARE IN mm.
2. ROUND OFF ALL SHARP CORNERS WITH 0.50 mm.
3. TOLERANCES WILL BE AS PER IS:6477-1983 UNLESS OTHERWISE SPECIFIED

PARTY'S NAME	WIPRO CONSUMER CARE & LIGHTING, BANGALORE
PARTY'S DRAWING No.	VBA D 0065
ALLOY & TEMPER	HE9 WP
DESCRIPTION	FURNITURE SECTION-POST 60x31