

4810

22510

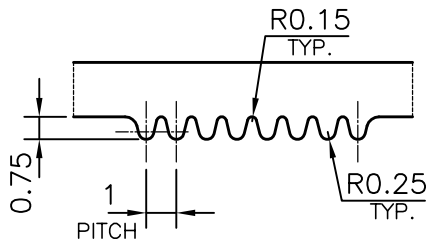

DETAIL OF "A"  
SCALE 4:1

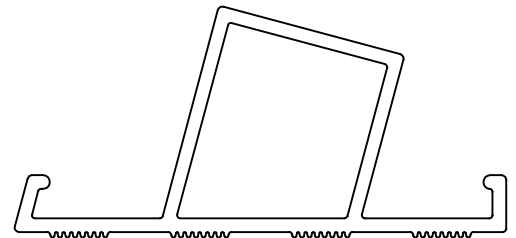

SCALE: - 1:1

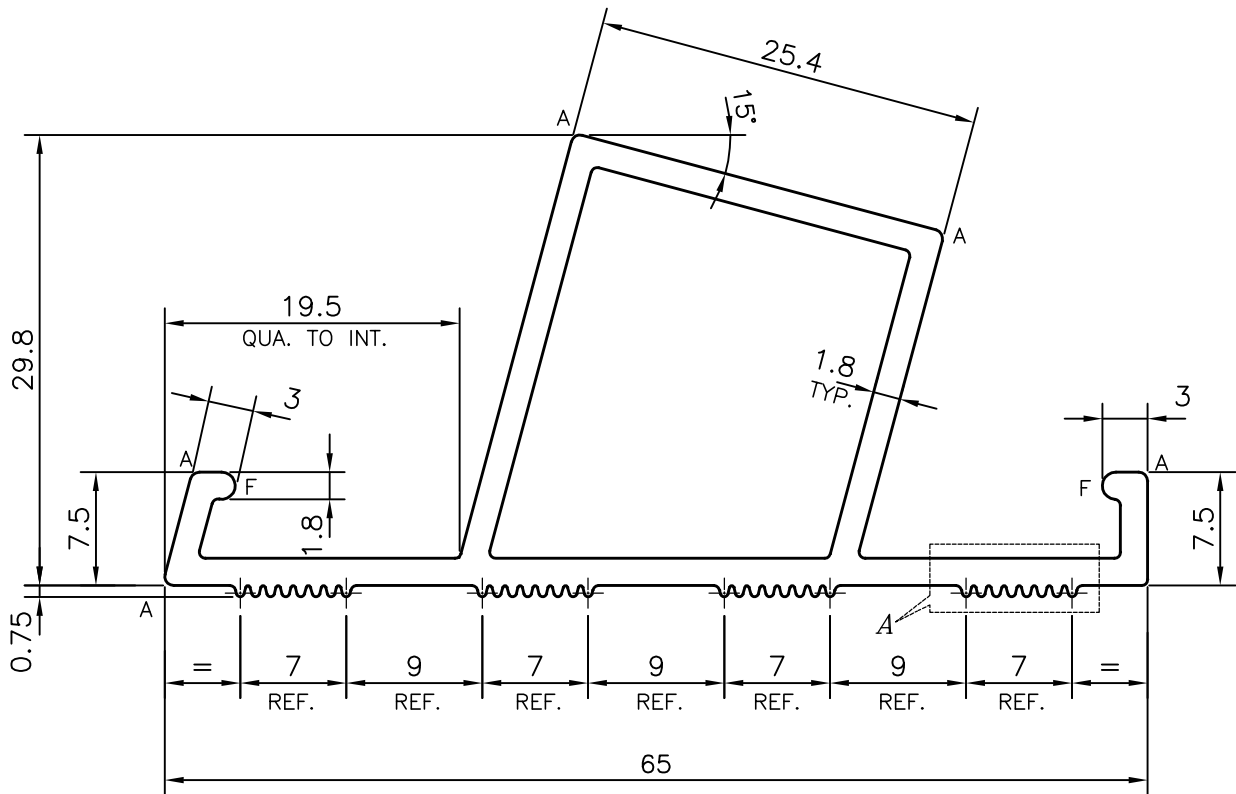

F = FULL RADIUS (2 PLACES)  
A = RADIUS 0.6 mm. (5 PLACES)



SYMBOL OF QUALITY  
AN ISO 9001 COMPANY

**JINDAL ALUMINIUM LTD.**  
BANGALORE-560073 (INDIA)

	NAME	DATE
DRAWN	PARVESH	12-07-2014
CHECKED		
APPROVED		

1. ALL DIMENSIONS ARE IN mm.
2. ROUND OFF ALL SHARP CORNERS WITH 0.40 mm.
3. TOLERANCES WILL BE AS PER IS:6477-1983 , UNLESS OTHERWISE SPECIFIED

SCALE	2:1
AREA mm <sup>2</sup>	286.889
PERIMETER mm.	238.81
WEIGHT kg/m	0.775
DRAWING No.	SECTION No.

PARTY'S NAME RAM SAROOP VIJAY KUMAR, DELHI

PARTY'S DRAWING No. -

ALLOY & TEMPER HE9 WP

DESCRIPTION LADDER SECTION

4810	-
22510	22510