

4876

22520

-

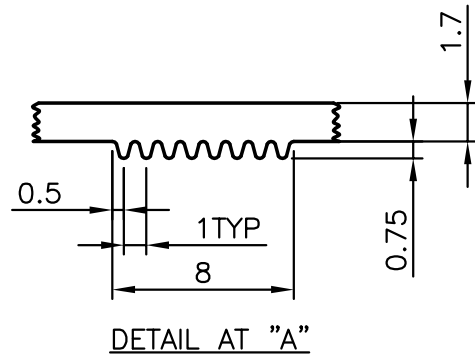
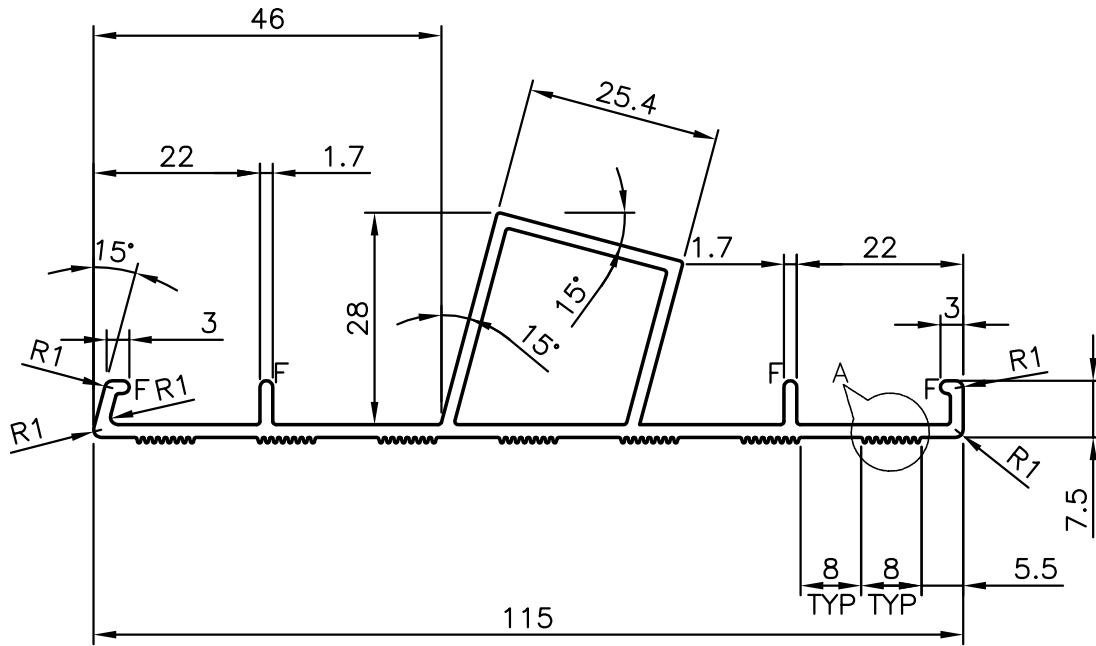

NOTE:-

F=FULL RADIUS (4 PLACES)



SYMBOL OF QUALITY
AN ISO 9001 COMPANY

JINDAL ALUMINIUM LTD.
BANGALORE-560073 (INDIA)

	NAME	DATE
DRAWN	PRASANNA.H.	19-12-2006
CHECKED		
APPROVED		

1. ALL DIMENSIONS ARE IN mm.
2. ROUND OFF ALL SHARP CORNERS WITH 0.40 mm.
3. TOLERANCES WILL BE AS PER IS:6477-1983 UNLESS OTHERWISE SPECIFIED

SCALE	1:1
AREA mm ²	384.364
PERIMETER mm.	384.181
WEIGHT kg/m	1.038

PARTY'S NAME	RAM SAROOP VIJAY KUMAR. DELHI
PARTY'S DRAWING No.	-
ALLOY & TEMPER	HE9 WP
DESCRIPTION	LADDER SECTION

DRAWING No.	SECTION No.
4876	4876
22520	22520
-	-