

P-3071
S643
4922
22523

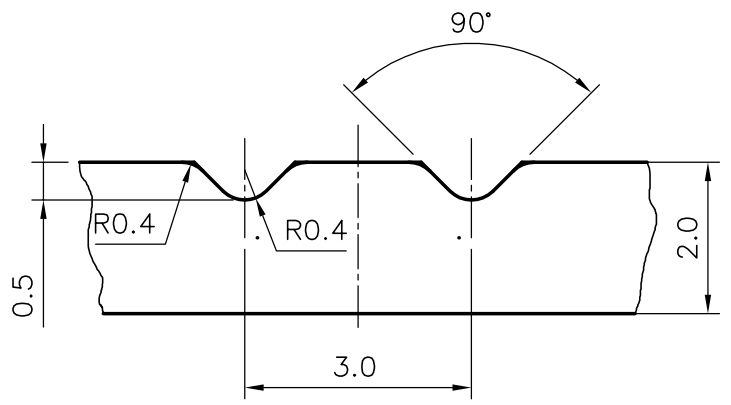

SCALE 10:1
DETAIL A

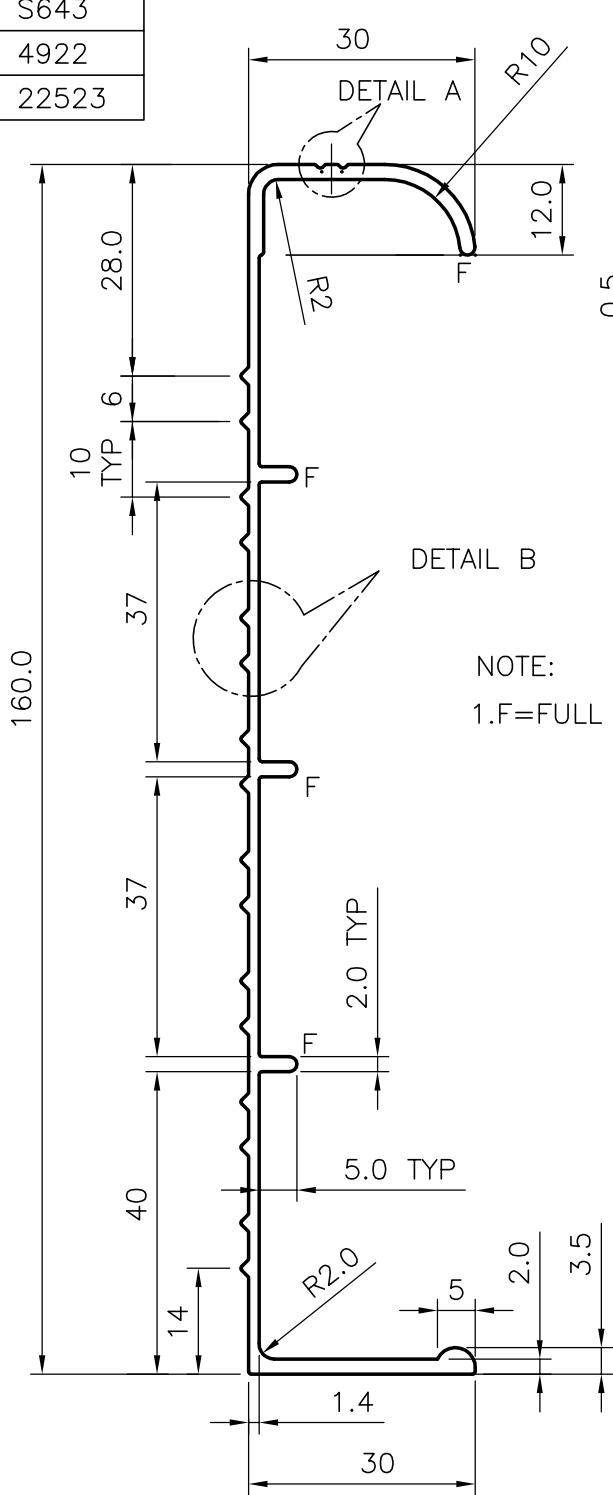
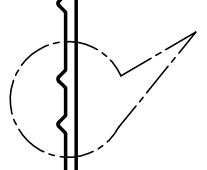

DETAIL B

NOTE:
1.F=FULL RADII 1.0 (4-PLCS)

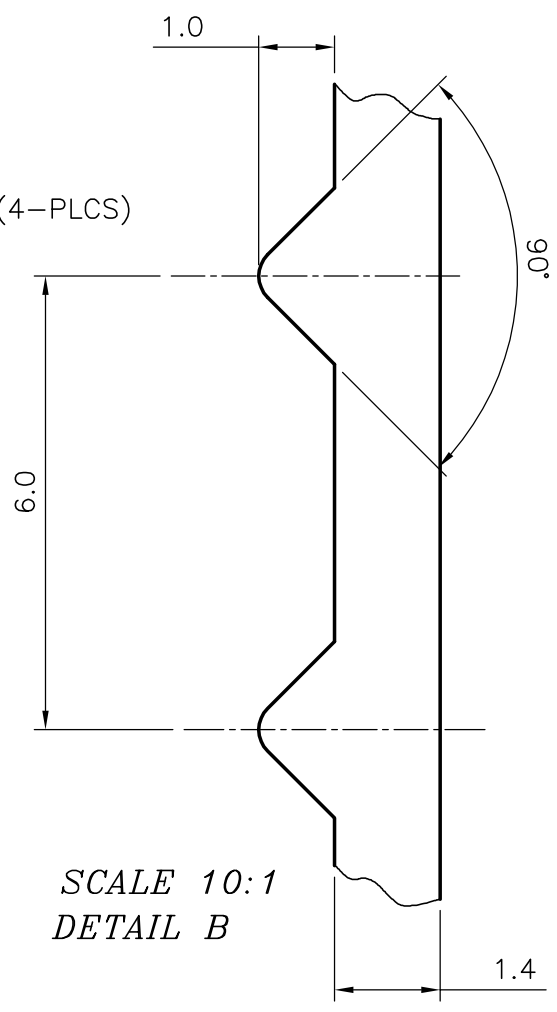

SCALE 10:1
DETAIL B

JINDAL ALUMINIUM LTD.
BANGALORE-560073

1. ALL DIMENSIONS ARE IN mm.
2. ROUND OFF ALL SHARP CORNERS WITH 0.4 mm.
3. TOLERANCES WILL BE AS PER IS: 3965-1981 ,UNLESS OTHERWISE SPECIFIED

PARTY'S NAME BATHLA ALUMINIUM (PVT) LTD.,BANGALORE		NAME		DATE	
		DRAWN		RANGASWAMY 30-01-01	
PARTY'S DRAWING No. AS PER DRAWING		CHECKED			
		APPROVED			
ALLOY & TEMPER 6005 T6		SCALE		1:1 & 10:1	
LENGTH -		WEIGHT kg/m		1.099	
DESCRIPTION LADDER SECTION		SECTION No.		22523	
		DRAWING No.		22523	