

P-4197

4923

22544

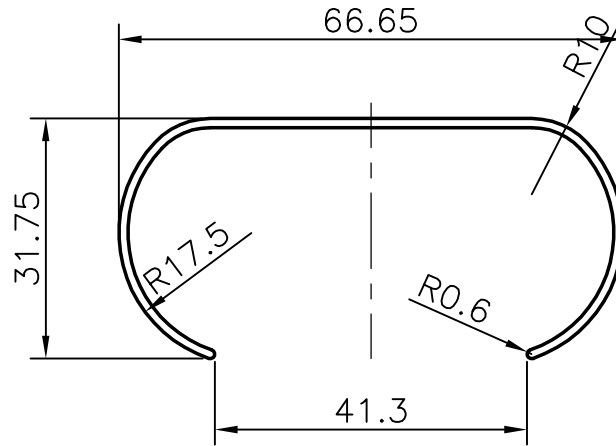

GENERAL WALL THICKNESS:- 1.20 mm.



SYMBOL OF QUALITY  
AN ISO 9002 COMPANY

**JINDAL ALUMINIUM LTD.**  
BANGALORE-560073 (INDIA)

	NAME	DATE
DRAWN	R.D.Sharma	22-04-03
CHECKED		
APPROVED		

1. ALL DIMENSIONS ARE IN mm.
2. ROUND OFF ALL SHARP CORNERS WITH 0.40 mm.
3. TOLERANCES WILL BE AS PER IS 3965-1981 UNLESS OTHERWISE SPECIFIED

SCALE	1:1
AREA mm <sup>2</sup>	151.7
PERIMETER mm.	254.7
WEIGHT kg/m	0.410
SECTION No.	22544
DRAWING No.	22544

PARTY'S NAME	GENERAL CATEGORY, MUMBAI MARKET
PARTY'S DRAWING No.	LIGHTER OF SECTION NO. 4811
ALLOY & TEMPER	HE9 WP
DESCRIPTION	LADDER SECTION