

P-4545

22546

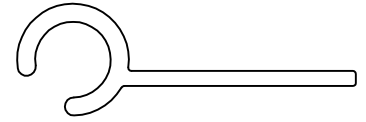

SCALE 1:1

MATCHING SECTION  
SCALE 1:1

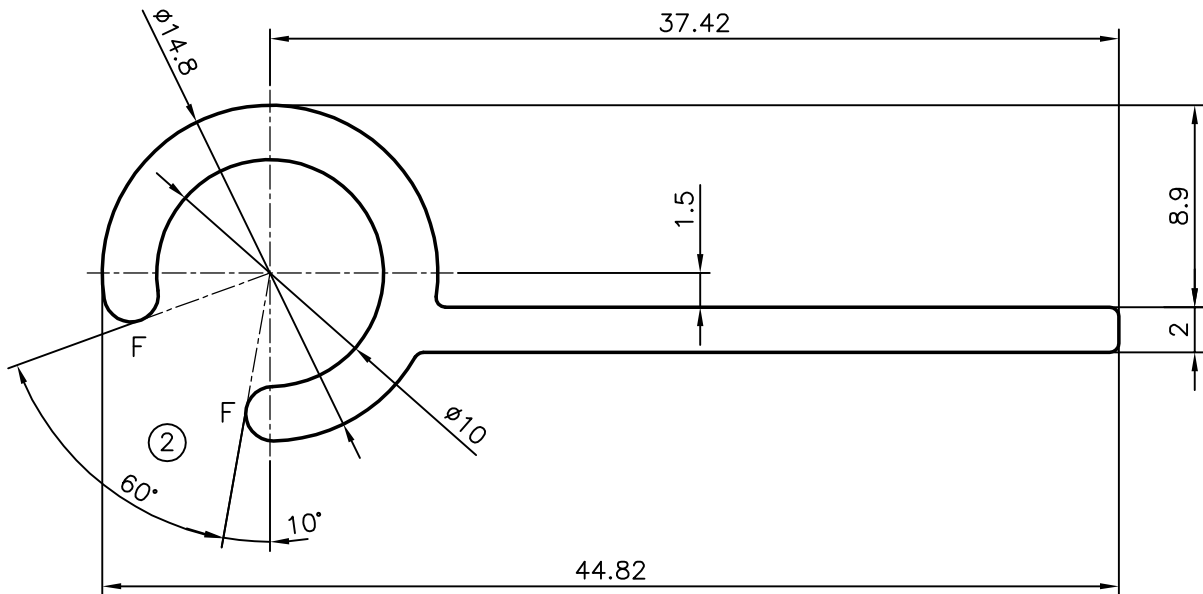
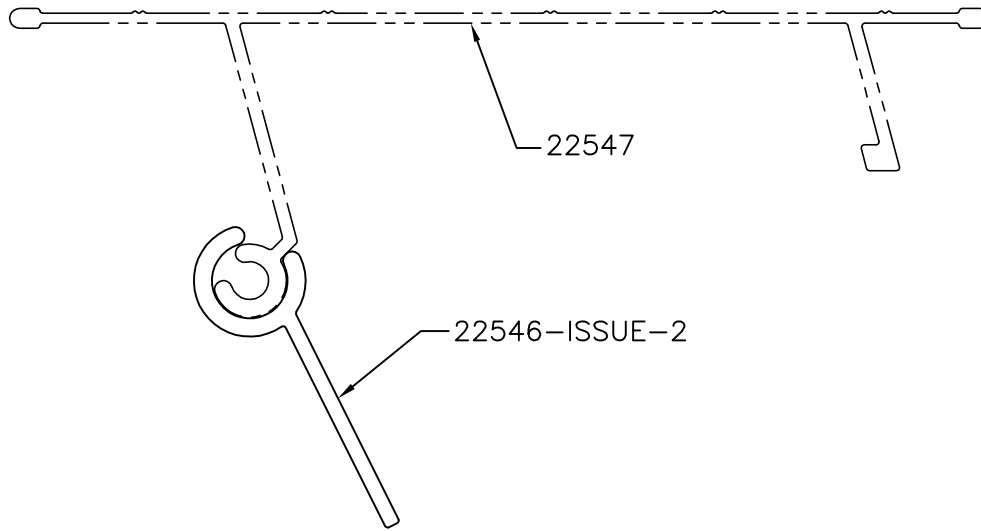

ISSUE -2 ANGLE CHANGED FROM 90° TO 60° &  
WEIGHT ALSO CHANGED FROM 0.350 kg/M TO 0.371 kg/M  
AS PER CUSTOMER REQUIREMENT



SYMBOL OF QUALITY  
AN ISO 9001 COMPANY

**JINDAL ALUMINIUM LTD.**  
BANGALORE-560073 (INDIA)

|          | NAME        | DATE       |
|----------|-------------|------------|
| DRAWN    | RAGHAVENDRA | 07-05-2008 |
| CHECKED  |             |            |
| APPROVED |             |            |

- ALL DIMENSIONS ARE IN mm.
- ROUND OFF ALL SHARP CORNERS WITH 0.40 mm.
- TOLERANCES WILL BE AS PER BSEN:755 UNLESS OTHERWISE SPECIFIED

|                      |         |
|----------------------|---------|
| SCALE                | 3:1     |
| AREA mm <sup>2</sup> | 137.588 |
| PERIMETER mm.        | 127.926 |
| WEIGHT kg/m          | 0.371   |

|                     |                                    |
|---------------------|------------------------------------|
| PARTY'S NAME        | ASIAN HARDWARE (PTE) LTD., COLOMBO |
| PARTY'S DRAWING No. | AS PER SAMPLE & AS PER REQUIREMENT |
| ALLOY & TEMPER      | 6063 T6                            |
| DESCRIPTION         | LADDER SECTION                     |

| DRAWING No. | SECTION No.   |
|-------------|---------------|
| P-4545      | -             |
| 22546       | 22546-ISSUE-2 |
|             |               |
|             |               |