

P-4032-1

X250

22548

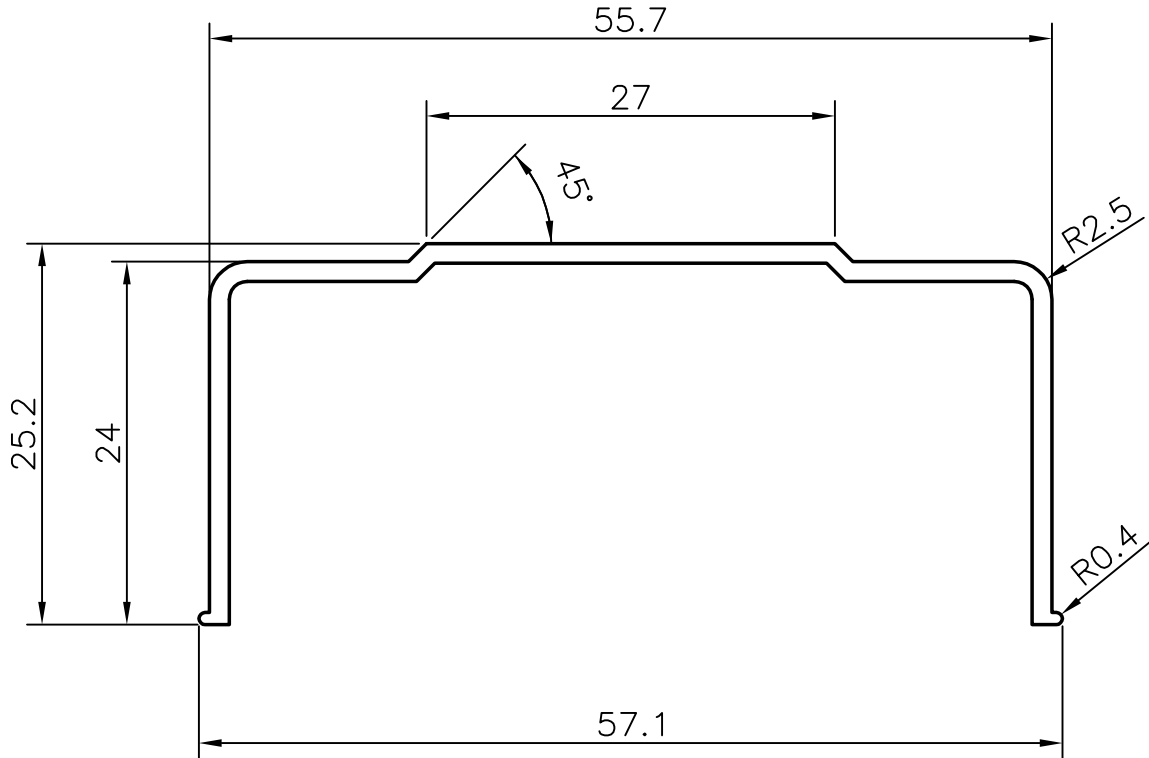
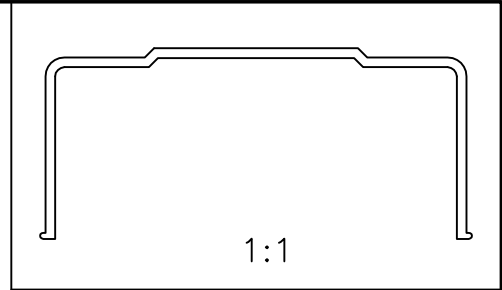

GENERAL WALL THICKNESS:- 1.30 mm. ^{+0.4}/_{-0.0}



SYMBOL OF QUALITY
AN ISO 9002 COMPANY

JINDAL ALUMINIUM LTD.
BANGALORE-560073 (INDIA)

	NAME	DATE
DRAWN	R.D.Sharma	27-11-02
CHECKED		
APPROVED		

1. ALL DIMENSIONS ARE IN mm.
2. ROUND OFF ALL SHARP CORNERS WITH 0.40 mm.
3. TOLERANCES WILL BE AS PER IS: 3965-1981 UNLESS OTHERWISE SPECIFIED

SCALE	2:1
AREA mm ²	131.6
PERIMETER mm.	205.7

PARTY'S NAME	J. S. ALUMINIUM (P) LTD., BANGALORE	WEIGHT kg/m	0.355
PARTY'S DRAWING No.	AS PER SAMPLE & SKETCH	SECTION No.	22548
ALLOY & TEMPER	HE9 WP	DRAWING No.	22548
DESCRIPTION	LADDER SECTION		