

P-4035

X253

22551

F = FULL RADIUS (4)

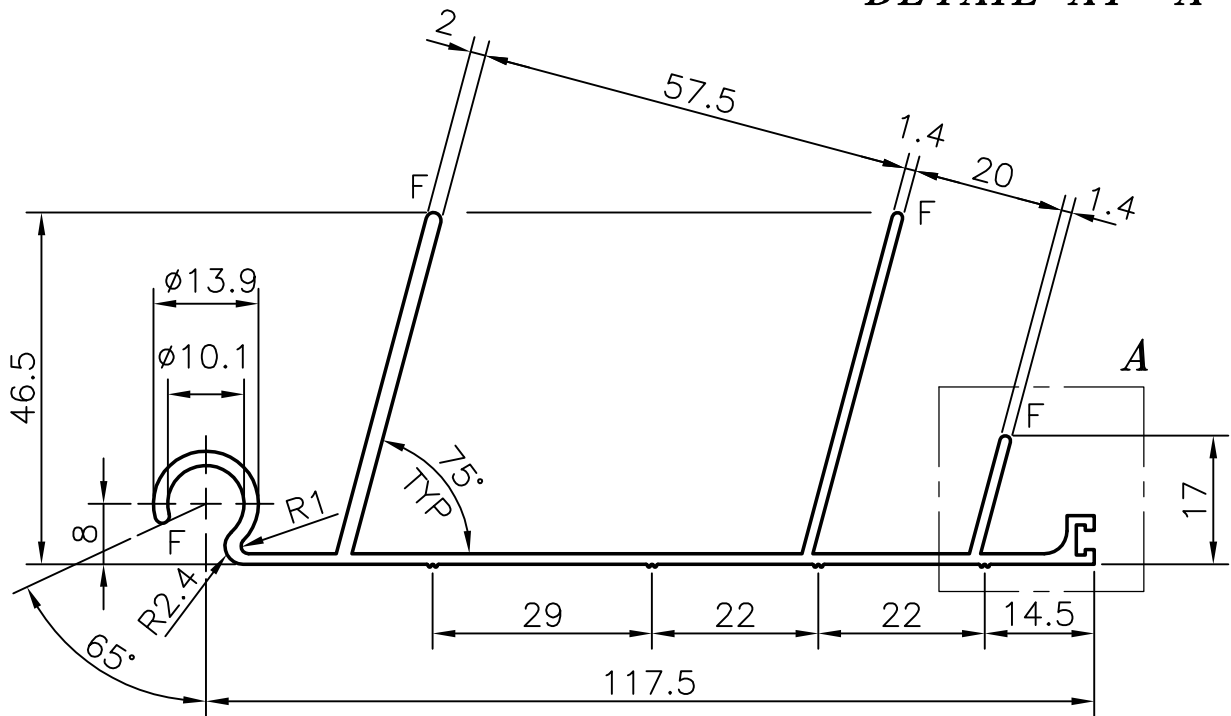
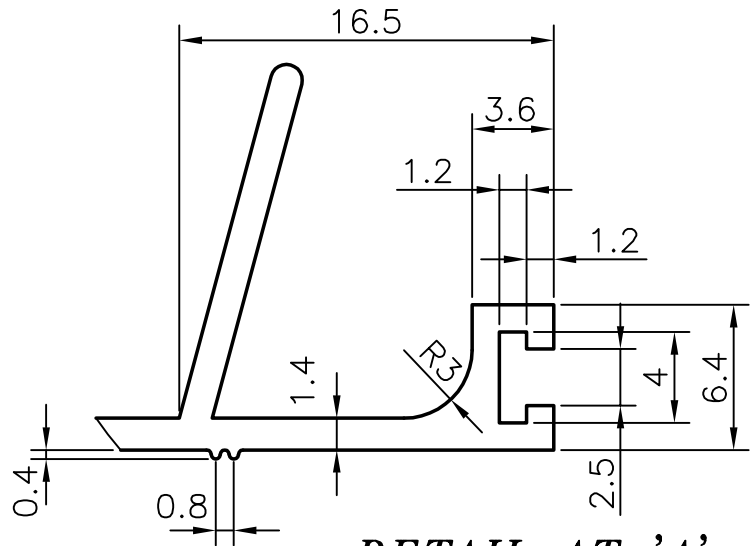

SYMBOL OF QUALITY
AN ISO 9002 COMPANY

JINDAL ALUMINIUM LTD.
BANGALORE-560073 (INDIA)

	NAME	DATE
DRAWN	R.D.Sharma	12-11-02
CHECKED		
APPROVED		

1. ALL DIMENSIONS ARE IN mm.
2. ROUND OFF ALL SHARP CORNERS WITH 0.40 mm.
3. TOLERANCES WILL BE AS PER IS: 3965-1981 UNLESS OTHERWISE SPECIFIED

SCALE	1:1 & 3:1
AREA mm ²	408.4
PERIMETER mm.	524.6
WEIGHT kg/m	1.103
SECTION No.	22551
DRAWING No.	22551

PARTY'S NAME	J. S. ALUMINIUM (P) LTD., BANGALORE
PARTY'S DRAWING No.	AS PER SAMPLE
ALLOY & TEMPER	HE9 WP
DESCRIPTION	LADDER SECTION