

P-7504

X711

22562

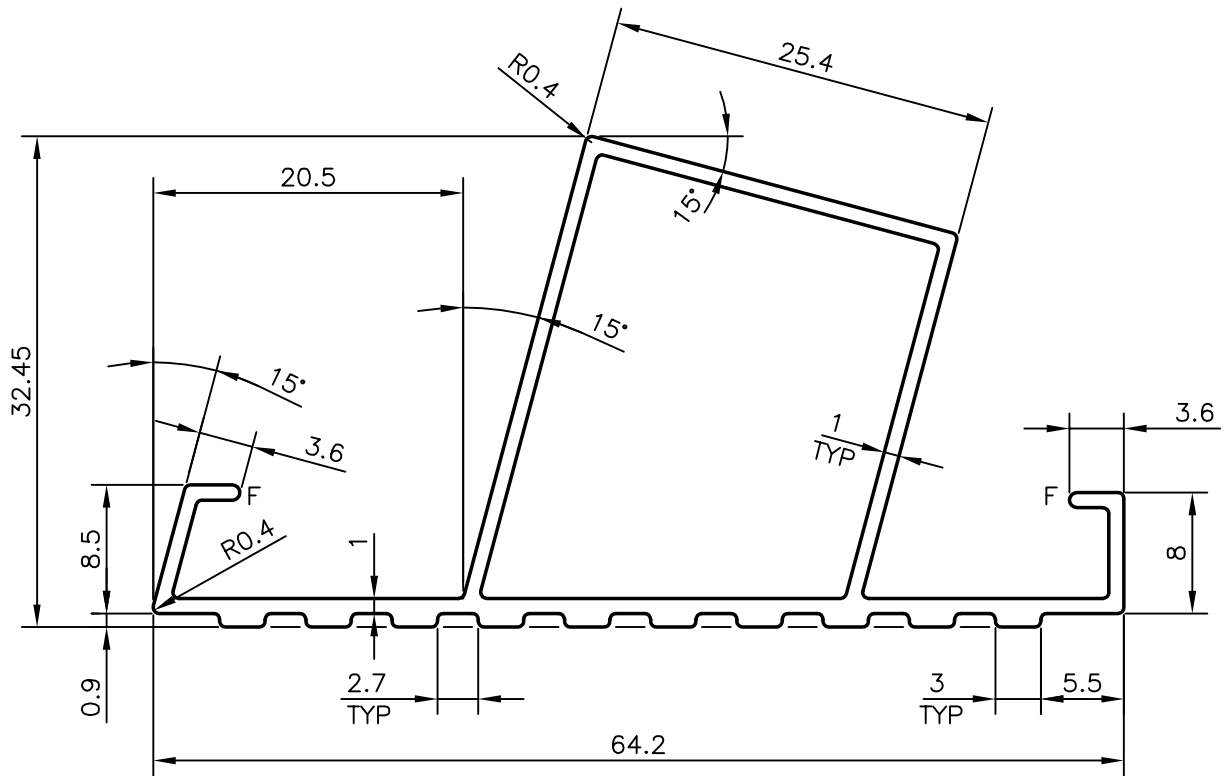
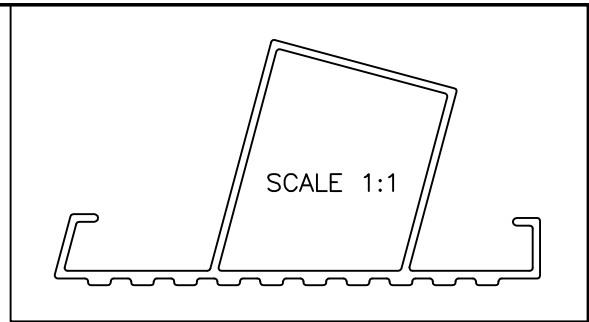

NOTE:-

1. GENERAL WALL THICKNESS = 1.00 mm
2. F = FULL RADIUS (2 PLACES)



SYMBOL OF QUALITY  
AN ISO 9001 COMPANY

**JINDAL ALUMINIUM LTD.**  
BANGALORE-560073 (INDIA)

	NAME	DATE
DRAWN	PRASANN.H	14-09-2007
CHECKED		
APPROVED		

1. ALL DIMENSIONS ARE IN mm.
2. ROUND OFF ALL SHARP CORNERS WITH 0.40 mm.
3. TOLERANCES WILL BE AS PER IS:6477-1983 UNLESS OTHERWISE SPECIFIED

SCALE	2:1
AREA mm <sup>2</sup>	191.207
PERIMETER mm.	234.236
WEIGHT kg/m	0.516

PARTY'S NAME	J.S. ALUMINIUM PVT. LTD., COIMBATORE
PARTY'S DRAWING No.	AS PER SAMPLE & AS PER REQUIREMENT
ALLOY & TEMPER	HE9 WP
DESCRIPTION	LADDER SECTION

DRAWING No.	SECTION No.
P-7504	-
X711	X711
22562	22562