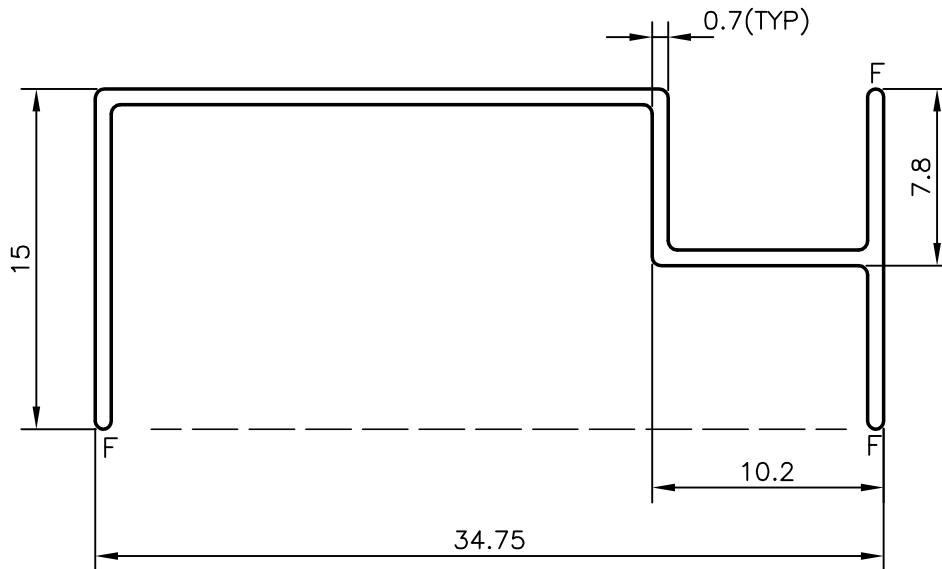

P-8600

22564

**NOTE:-**

1. *F* = FULL RADIUS (3 PLACES)
2. WEIGHT PER 3658 mm LONG PIECE = 0.486 kg (AVERAGE)

PLEASE CONFIRM ALL THE DIMENSIONS AND MATCH WITH YOUR MATCHING COMPONENT

PLEASE SPECIFY THE EXPOSED SURFACE IN THE DRAWING WHEREVER BETTER FINISH REQUIRED.

 SYMBOL OF QUALITY AN ISO 9001 COMPANY	JINDAL ALUMINIUM LTD. BANGALORE-560073 (INDIA)	DRAWN	NAME	DATE
		CHECKED	ABHARANI	30-08-2008
1. ALL DIMENSIONS ARE IN mm. 2. ROUND OFF ALL SHARP CORNERS WITH 0.40 mm. 3. TOLERANCES WILL BE AS PER IS:3965-1981 UNLESS OTHERWISE SPECIFIED		APPROVED		
		SCALE		3:1
PARTY'S NAME VIGNESWARA COTTAGE INDUSTRIES, COIMBATORE		AREA mm ²		49.226
		PERIMETER mm.		140.025
PARTY'S DRAWING No. LIGHTER OF SECTION NO. 22557		WEIGHT kg/m		0.133
		DRAWING No.		SECTION No.
ALLOY & TEMPER HE9 WP		P-8600		-
		22564		22564
DESCRIPTION LOUVERS SECTION				