

P-8398-3

X959

22569

MATCHING COMPONENT

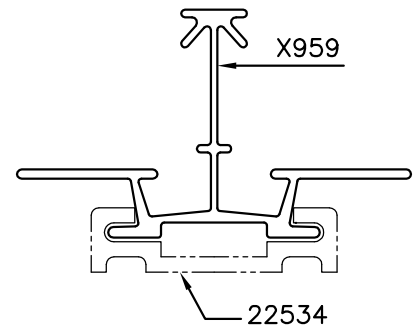

SCALE 1:1

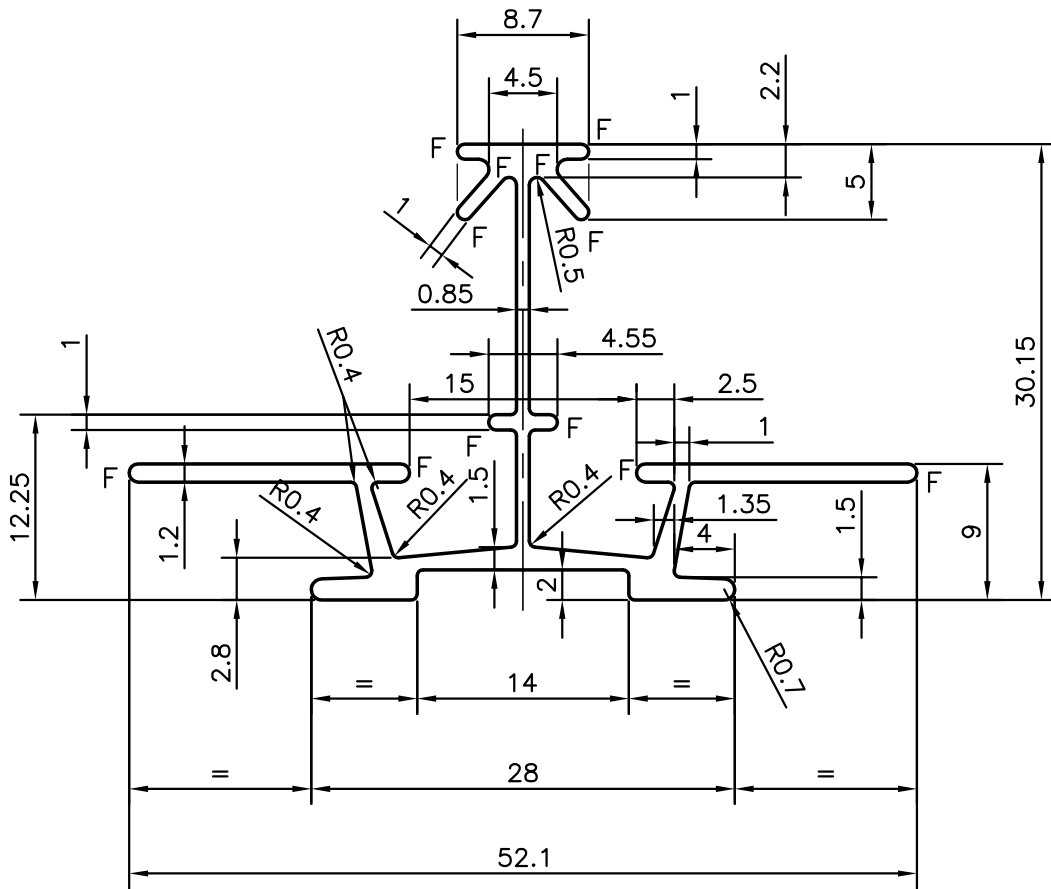

F = FULL RADIUS (12 PLACE)



SYMBOL OF QUALITY
AN ISO 9001 COMPANY

JINDAL ALUMINIUM LTD.
BANGALORE-560073 (INDIA)

	NAME	DATE
DRAWN	PRASANNA.H	07-07-2008
CHECKED		
APPROVED		

1. ALL DIMENSIONS ARE IN mm.
2. ROUND OFF ALL SHARP CORNERS WITH 0.40 mm.
3. TOLERANCES WILL BE AS PER IS:3965-1981 UNLESS OTHERWISE SPECIFIED

SCALE	2:1
AREA mm ²	148.14
PERIMETER mm.	240.991
WEIGHT kg/m	0.400

PARTY'S NAME	KAILASHPURAM ASSOCIATES, CHENNAI
PARTY'S DRAWING No.	AS PER SAMPLE & CUSTOMER REQUIREMENT
ALLOY & TEMPER	HE9 WP
DESCRIPTION	GLAZING BAR

DRAWING No.	SECTION No.
P-8398-3	-
X959	X959
22569	22569