

P-11244-3

S3068

22570

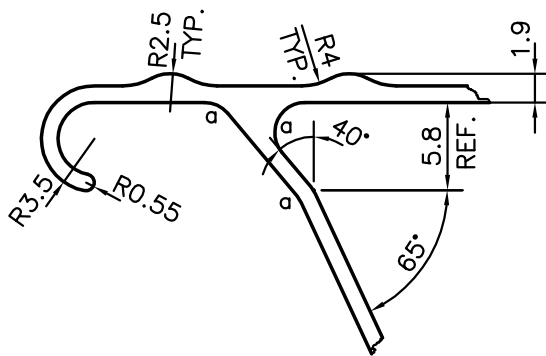
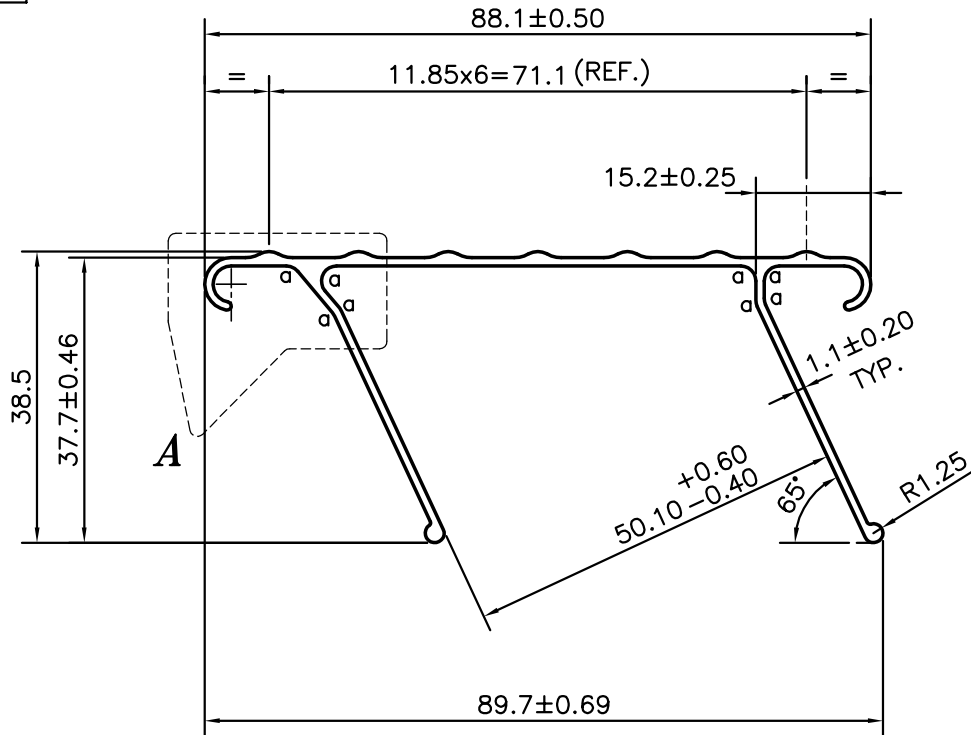

DETAIL OF 'A'
SCALE 2:1

a = RADIUS 2 mm. (8 PLACES)

 SYMBOL OF QUALITY AN ISO 9001 COMPANY	JINDAL ALUMINIUM LTD. BANGALORE-560073 (INDIA)	DRAWN	NAME	DATE
		CHECKED	PARVESH	11-10-2011
1. ALL DIMENSIONS ARE IN mm. 2. ROUND OFF ALL SHARP CORNERS WITH 0.40 mm. 3. TOLERANCES WILL BE AS PER, IS:3965-1981 UNLESS OTHERWISE SPECIFIED	BATHLA ALUMINIUM PVT. LTD., BANGALORE	APPROVED	S.S.GARG	12-10-2011
		SCALE		1:1
		AREA mm ²	225.698	
PARTY'S NAME	D 005 000 00	PERIMETER mm.	360.709	
		WEIGHT kg/m	0.609	
PARTY'S DRAWING No.	HE9 WP	DRAWING No.	SECTION No.	
		P-11244-3	-	
ALLOY & TEMPER	STEP LADDER SECTION	S3068	S3068	
		22570	22570	
DESCRIPTION				