

P-12891

22571

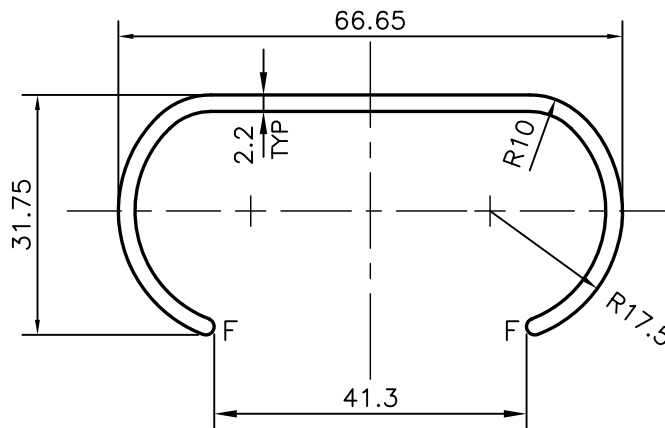

TOLERANCE CHART CD = CIRCUMSCRIBING CIRCLE

CD ≤ 100	100 < CD ≤ 200	200 < CD < 300	300 < CD < 500
UPTO 10mm - ±0.40	±0.50	±0.55	±0.60
10.0 - 25.0 - ±0.50	±0.70	±0.80	±0.90
25.0 - 50.0 - ±0.80	±0.90	±1.0	±1.20
50.0 - 100.0 - ±1.0	±1.20	±1.30	±1.60
100 - 150 - -	±1.50	±1.70	±1.80
150 - 200 - -	±1.9	±2.20	±2.40
200 - 300 - -	-	±2.50	±2.80
300 - 450 - -	-	-	±3.50

2. F = FULL RADIUS (2)



SYMBOL OF QUALITY
AN ISO 9001 COMPANY

JINDAL ALUMINIUM LTD.
BANGALORE-560073 (INDIA)

	NAME	DATE
DRAWN	J.P.KAUSHIK	09-07-2013
CHECKED		
APPROVED	S.S.GARG	12-07-2013
SCALE		1:1
AREA mm ²		270.97
PERIMETER mm.		249.792
WEIGHT kg/m		0.732
DRAWING No.	SECTION No.	
P-12891	-	
22571	22571	

1. ALL DIMENSIONS ARE IN mm.
2. ROUND OFF ALL SHARP CORNERS WITH 0.40 mm.
3. TOLERANCES WILL BE AS PER BS:EN-755-9 UNLESS OTHERWISE SPECIFIED

PARTY'S NAME	ASIAN HARDWARE, SRILANKA
PARTY'S DRAWING No.	LIGHTER OF SECTION No:-22503
ALLOY & TEMPER	6005 T6
DESCRIPTION	LADDER SECTION