

P-12664

S3715

22584

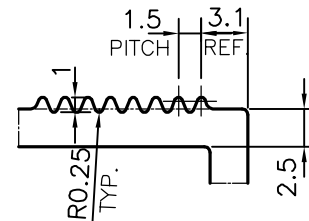
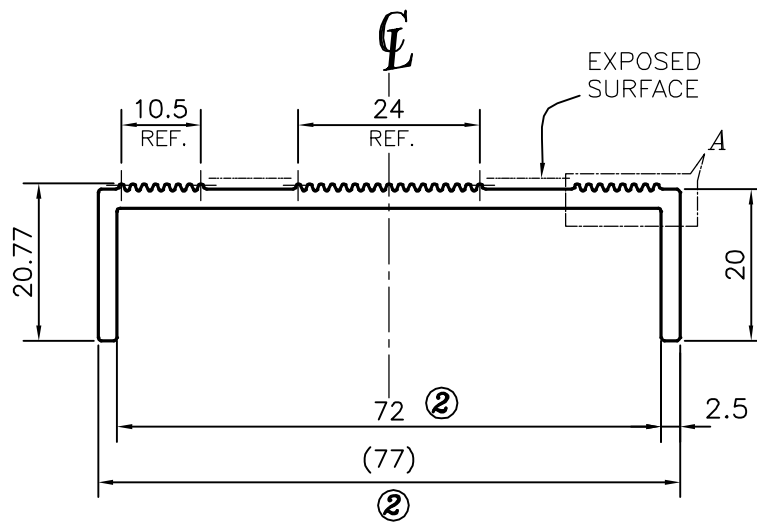

DETAIL OF "A"
SCALE 2:1

ISSUE (2) :-

1. DIMENSIONS INCREASED FROM 70 mm TO 77 mm.
2. DIMENSION 72 mm. ADDED.
3. WEIGHT ALSO INCREASED FROM 0.745 kg/m. TO 0.793 kg/m

TOLERANCES ON OVERALL WIDTHS & WIDTHS ACROSS FLATS OF BARS, & REGULAR SECTIONS

UPTO 6.40mm - ±0.20	UPTO 32.0mm - ±0.38	UPTO 120.0mm - ±0.85	UPTO 320.00mm - ±1.70
UPTO 10.0mm - ±0.23	UPTO 50.0mm - ±0.46	UPTO 160.0mm - ±1.02	
UPTO 12.0mm - ±0.25	UPTO 60.0mm - ±0.53	UPTO 200.0mm - ±1.14	
UPTO 16.0mm - ±0.28	UPTO 80.0mm - ±0.69	UPTO 250.0mm - ±1.40	
UPTO 25.0mm - ±0.30	UPTO 100.0mm - ±0.75	UPTO 300.0mm - ±1.65	



SYMBOL OF QUALITY
AN ISO 9001 COMPANY

JINDAL ALUMINIUM LTD.
BANGALORE-560073 (INDIA)

	NAME	DATE
DRAWN	PARVESH	30-04-2013
CHECKED		
APPROVED	S.S.GARG	13-05-2013

1. ALL DIMENSIONS ARE IN mm.
2. ROUND OFF ALL SHARP CORNERS WITH 0.40 mm.
3. TOLERANCES WILL BE AS PER IS:3965-1981 , UNLESS OTHERWISE SPECIFIED

SCALE	1:1
AREA mm ²	293.57
PERIMETER mm.	265.373
WEIGHT kg/m	0.793

PARTY'S NAME	ENJACKAL ALUMINIUM INDUSTRIES, ERNAKULAM
PARTY'S DRAWING No.	MODIFIED OF SECTION No. 22508
ALLOY & TEMPER	HE9 WP
DESCRIPTION	LADDER SECTION

DRAWING No.	SECTION No.
P-12664	-
S3715	S3715 (ISSUE-2)
22584	22584