

P-15902-1

22588

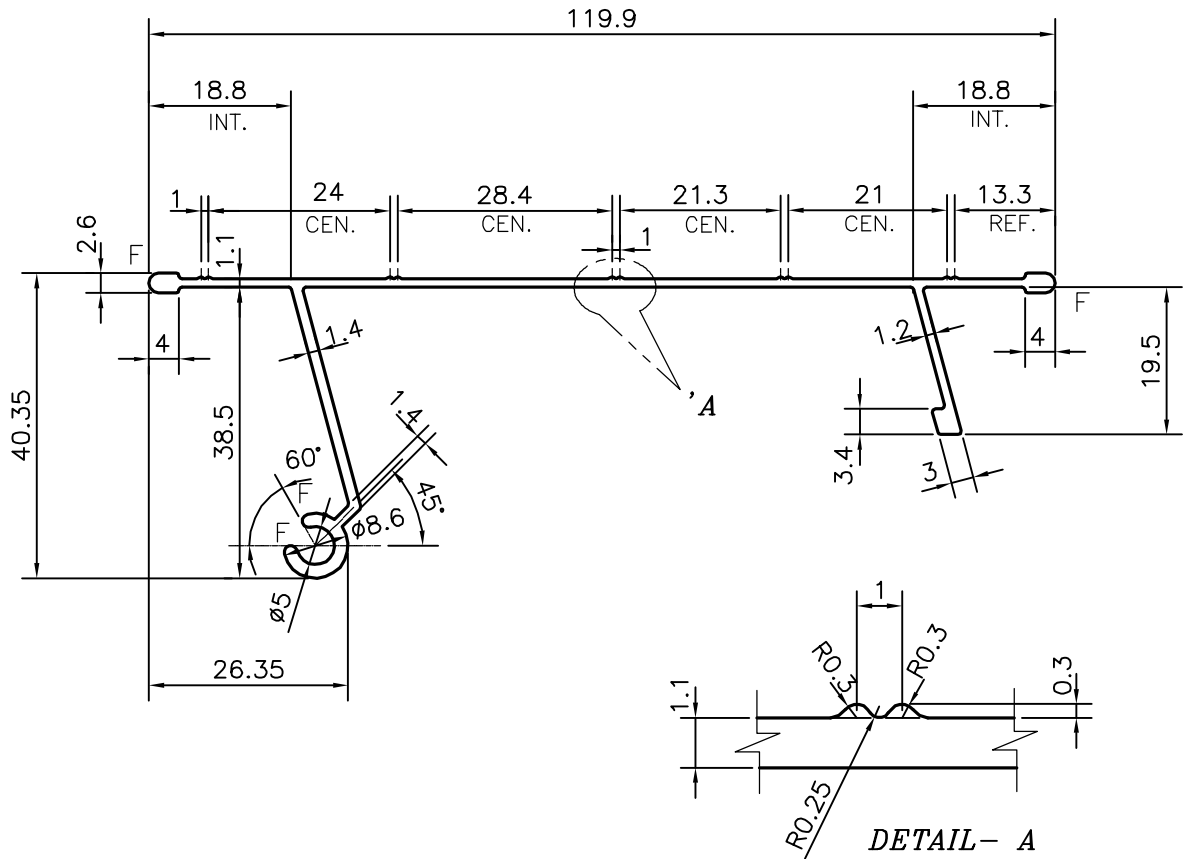

F = FULL RADIUS

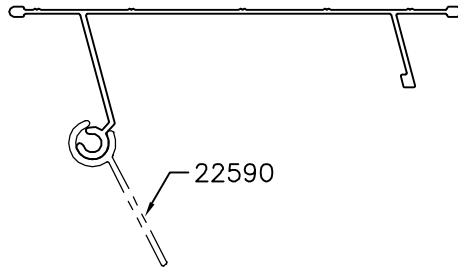

SYMBOL OF QUALITY
AN ISO 9001 COMPANY

JINDAL ALUMINIUM LTD.
BANGALORE-560073 (INDIA)

	NAME	DATE
DRAWN	J.P.KAUSHIK	03-06-2016
CHECKED		
APPROVED	S.S. GARG	16-06-2016
SCALE		1:1
AREA mm ²		252.357
PERIMETER mm.		389.756
WEIGHT kg/m		0.681
DRAWING No.	SECTION No.	
P-15902-1	-	
22588	22588	

1. ALL DIMENSIONS ARE IN mm.
2. ROUND OFF ALL SHARP CORNERS WITH 0.40 mm.
3. TOLERANCES WILL BE AS PER,BS:EN-755-9 UNLESS OTHERWISE SPECIFIED

PARTY'S NAME	ASIAN HARDWARE (PTE) LTD.,. COLOMBO
PARTY'S DRAWING No.	MODIFIED OF 22547
ALLOY & TEMPER	6063 T6
DESCRIPTION	LADDER SECTION