

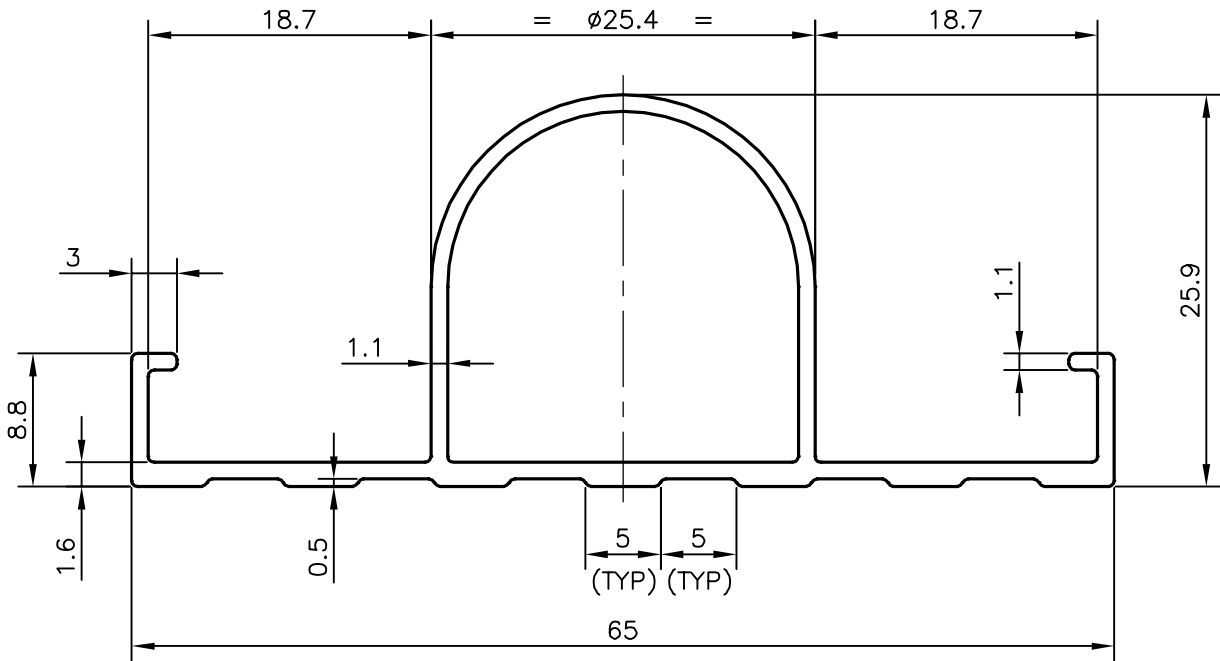

P-14883
X1898
22595

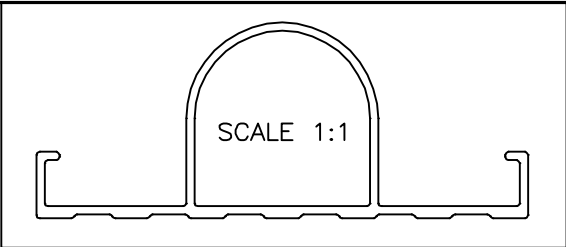

 SYMBOL OF QUALITY AN ISO 9001 COMPANY	JINDAL ALUMINIUM LTD. BANGALORE-560073 (INDIA)			NAME	DATE
		DRAWN	J.P.KAUSHIK	15-07-2015	
1. ALL DIMENSIONS ARE IN mm. 2. ROUND OFF ALL SHARP CORNERS WITH 0.40 mm. 3. TOLERANCES WILL BE AS PER IS:6477-1983 UNLESS OTHERWISE SPECIFIED		CHECKED			
		APPROVED	B.NATARAJA	18-07-2015	
PARTY'S NAME SRK LADDERS, PUTTUR (DK)		SCALE		2:1	
		AREA mm ²		176.352	
PARTY'S DRAWING No. LIGHTER OF SECTION No:-22566		PERIMETER mm.		207.385	
		WEIGHT kg/m		0.476	
ALLOY & TEMPER HE9 WP		DRAWING No.	SECTION No.		
		P-14883	-		
DESCRIPTION LADDER SECTION		X1898	X1898		
		22595	22595		