

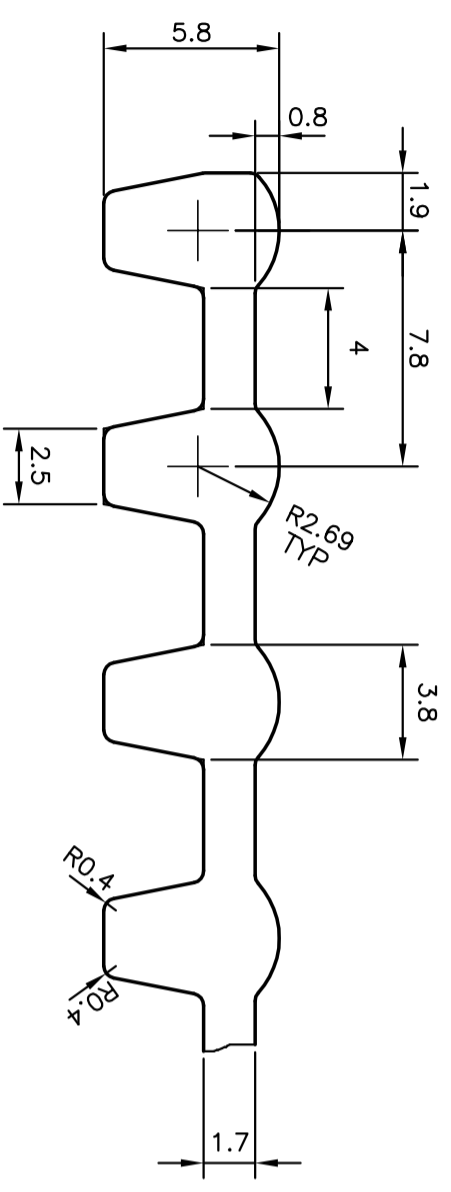

P-9623
S2383
22622

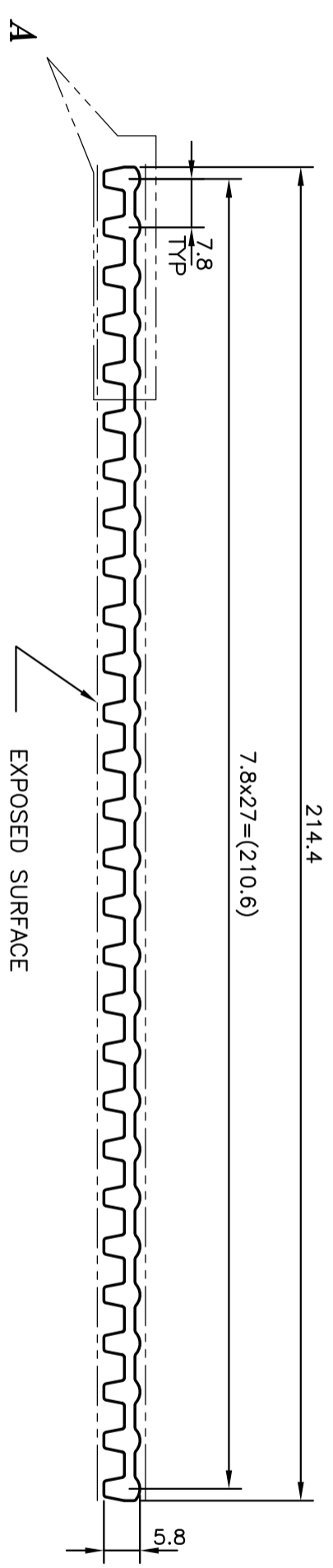

DETAIL "A"
(4:1)

 SYMBOL OF QUALITY AN ISO 9001 COMPANY	JINDAL ALUMINIUM LTD. BANGALORE-560073 (INDIA)		DRAWN J.P. KAUSHIK 07-11-2009	NAME J.P. KAUSHIK DATE 07-11-2009
	1. ALL DIMENSIONS ARE IN mm. 2. ROUND OFF ALL SHARP CORNERS WITH 0.40 mm. 3. TOLERANCES WILL BE AS PER IS:3965-1981, UNLESS OTHERWISE SPECIFIED		CHECKED APPROVED	SCALE 1:1
PARTY'S NAME ATLANTA PAINTS, JODHPUR	PARTY'S DRAWING No. AS PER DRAWING	AREA mm ² 714.772	PERIMETER mm. 583.554	WEIGHT kg/m 1.93
ALLOY & TEMPER 6063 T6	DESCRIPTION EXPANDABLE GRILL SECTION	DRAWING No. P-9623	SECTION No. -	DRAWING No. S2383 22622